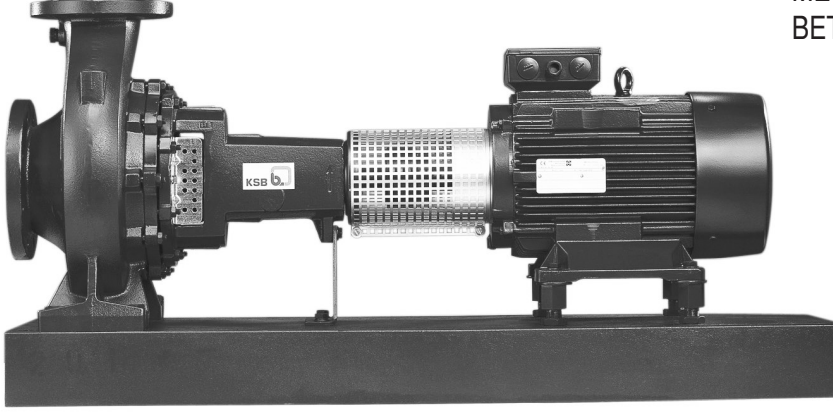

Spiral Gövdeli Santrifüj Pompa

MEGA : TS EN 25199 Class II
BETA : TS EN ISO 9908 Class III

**Kullanım Alanları**

- Su temini
- Yağmurlama-tarım
- Havalandırma
- Sıcak su
- Deniz suyu
- Az kirlı sular
- Yağlar
- Yangın söndürme
- Isıtma
- İçme suyu
- Soğutma suyu
- Havuz suyu
- Kondens suyu
- Muhtelif endüstriyel akışkanlar

İşletme Bilgileri

Debi	: 540 m ³ /h'e kadar.
Basma Yüksekliği	: 90 m'ye kadar.
Pompa Ölçüleri	: 32-150 mm
Çalışma Basıncı	Beta : 10 bar'a kadar. Mega : 16 bar'a kadar.
Çalışma Sıcaklığı	: -30°C ile +140°C arası

Dizayn

Yatay salyangoz gövdeli, sondan emişli, tek kademeli, arkadan çekip çıkartılabilen tip santrifüj pompa. Dizaynı optimize edilmiş çark ile yüksek verimlilik ve düşük enerji sarfiyatı sağlanmıştır.

Yataklar

MEGA : Sıvı yağlamalı, tek sıra sabit bilyalı rulman.
BETA : Bakımsız tip, gres yağlı, sabit bilyalı rulman.

Mil Sızdırmazlığı

EN 12756'ya uygun mekanik salmastra veya yumuşak salmastra.

Tanımlama

Tipi	MEGA	100 - 315	G	1
Basma ağız DN				
Nominal Çark çapı-mm				
Malzeme Kodu (G,M,B,S,C)				
Salmastra Tipi:				
1 - Yumuşak Salmastra				
16 - Standart maks. 140°C su için mekanik salmastra				

Motor

Üç faz sincap kafesli asenkron motor.	
2,2 kW'a kadar	: 220-240V / 380-420V
3 kW ve üzeri	: 380-420V / 660-725V
Dizayn	: IMB3
Koruma sınıfı	: IP54 veya IP55
İzolasyon sınıfı	: F (opsiyonel olarak 3 termistörlü)
Çalışma modu	: Sürekli S1

Kaplin

Flender marka elastik kaplin veya opsiyonel olarak aralıklı kaplin.

Kaplin Koruyucu

EN 294'e uygun kaplin koruyucu.

Kaide

Pompa ve motor için çelik kaide.

Seçim Eğrileri
50 Hz. 1450 d/dak.

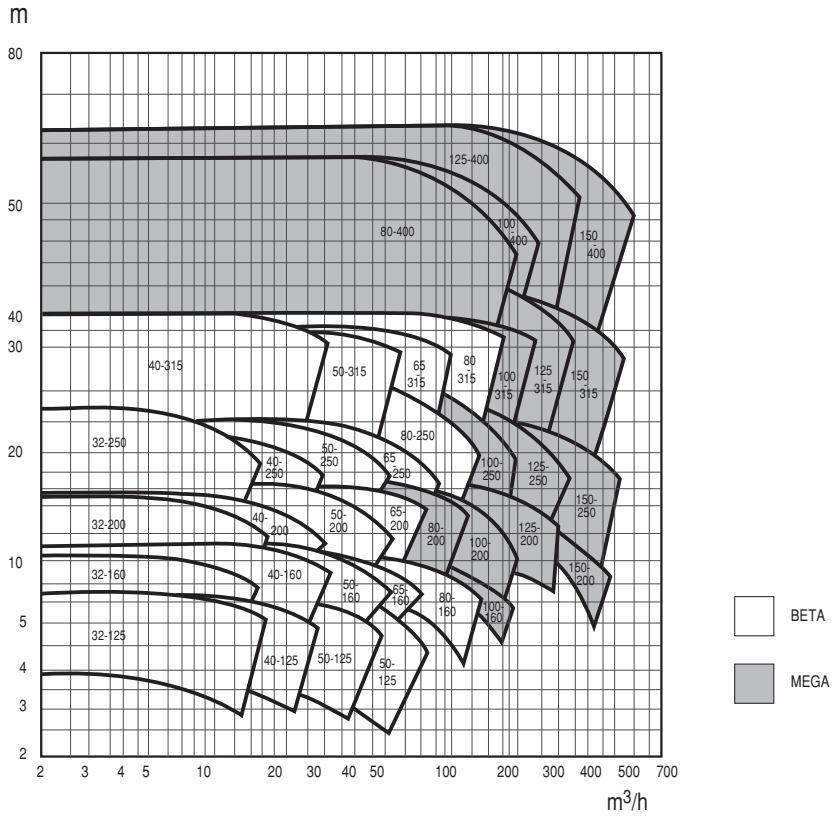

50 Hz. 2900 d/dak.

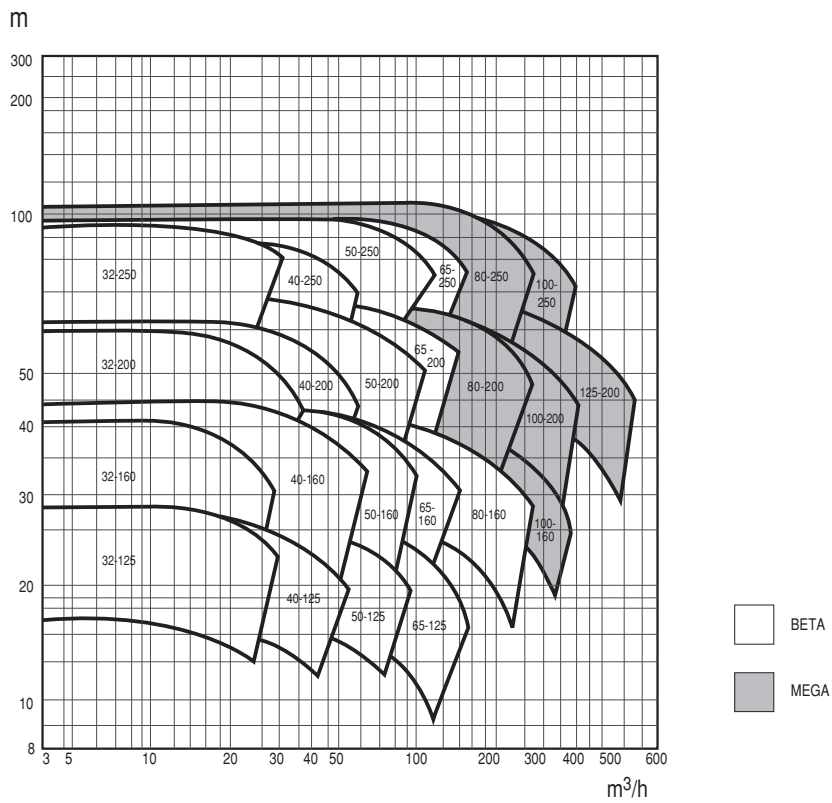

Malzeme Kombinasyonları

	BETA/MEGA G	BETA/MEGA M	BETA/MEGA B
Gövde	JL 1040 (Gri dökme demir)	JL 1040 (Gri dökme demir)	CC 480 K-GS (Bronz)
Baskı kapağı	JL 1040 (Gri dökme demir)	JL 1040 (Gri dökme demir)	CC 480 K-GS (Bronz)
Çark	JL 1040 (Gri dökme demir)	CC 480 K-GS (Bronz)	CC 480 K-GS (Bronz)
Mil	ST 70 (Karbon çeliği)	ST 70 (Karbon çeliği)	1.4401 (P.Çelik)
Yatak konsülü	JL 1040 (Gri dökme demir)	JL 1040 (Gri dökme demir)	JL 1040 (Gri dökme demir)

	BETA/MEGA S	BETA/MEGA C
Gövde	JS 1025 (Küresel grafitli dökme demir)	1.4401 (P.Çelik)
Baskı kapağı	JS 1025 (Küresel grafitli dökme demir)	1.4401 (P.Çelik)
Çark	JL 1040 (Gri dökme demir)	1.4401 (P.Çelik)
Mil	ST 70 (Karbon çeliği)	1.4401 (P.Çelik)
Yatak konsülü	JL 1040 (Gri dökme demir)	JL 1040 (Gri dökme demir)

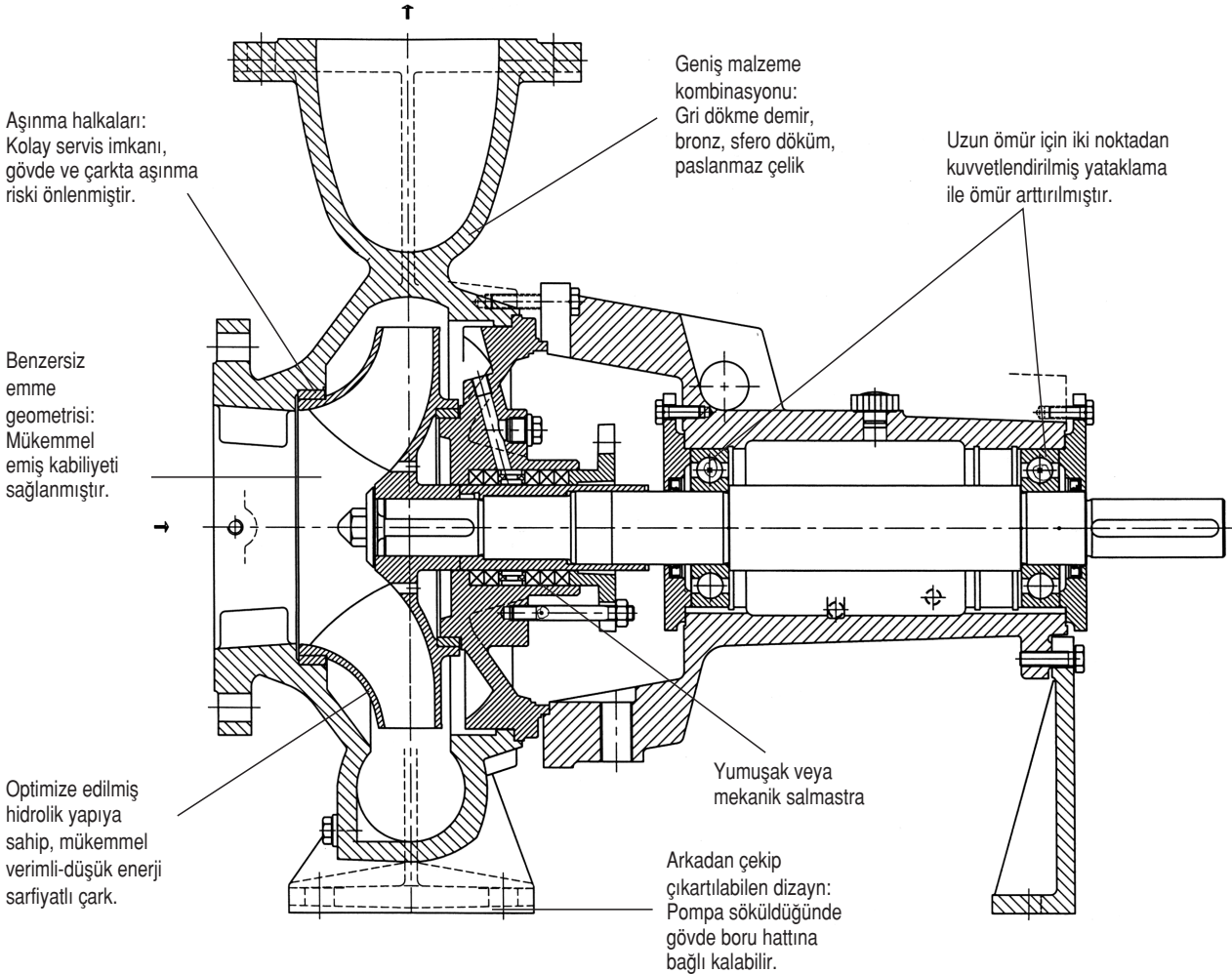
Mega'nın Üstün Özellikleri

SIVI	Çalışma Limitleri	MALZEME Gövde/Çark				
		JL 1040/JL 1040	JL 1040/ CC 480 K-GS	CC 480 K-GS/ CC 480 K-GS	JS 1025/JL 1040	1-4401 / 1-4401 (P-Çelik)
SU ÇEŞİTLERİ 1)		G	M	B	S	C
Hafif tuzlu, acı su	t ≤ 25°C			X		
Kondens suyu ²⁾	t ≤ 120°C	X				
Soğutma suyu (antifiriz içermeyen)	t ≤ 60°C	X				
Soğutma suyu PH ≥ 7,5 (antifirizli) ⁴⁾	t ≤ 30°C, t ≤ 110°C	X				
Baraj suyu	t ≤ 60°C		X			
İçme suyu	t ≤ 60°C		X			
Yangın söndürme suyu	t ≤ 35°C		X			
Tam tuzu alınmış su ²⁾	t ≤ 120°C					X
Isıtma suyu ²⁾	t ≤ 120°C	X				
Isıtma suyu ²⁾	t ≤ 140°C	X				
Isıtma suyu ³⁾	t ≤ 110°C	X				
Kısmen tuzu alınmış su	t ≤ 120°C					X
Saf su ⁵⁾	t ≤ 60°C	X				
Ham su	t ≤ 60°C	X				
Deniz suyu	t ≤ 25°C			X		
Çok az kirlı su	t ≤ 60°C	X				
Yüzme havuzu suyu (tatlı su)	t ≤ 60°C	X				
Yüzme havuzu suyu (deniz suyu) ^{1) 4)}	t ≤ 40°C			X		
Soğutucular ve soğutma tuz çözeltisi						
Soğutma tuz çözeltisi, inorganik PH>7,5	t ≥ -30°C, t ≤ 25°C	X				
Antifirizli su, PH>7,5	t ≥ -30°C, t ≤ 110°C	X				
Yakıtlar ve Yağlar						
Dizel yakıtı, fuel-oil EL	t ≤ 60°C				X	
Delik açma işlemleri için yağ emülsiyonları	t ≤ 60°C	X				
Yağlama yağı, türbin yağı (SDF yağları için uygun değil)	t ≤ 80°C				X	
Yağ ve su karışımları	t ≤ 60°C	X				

Çalışma Limitleri ve liste dışındaki sıvılar için KSB Ofislerine danışınız.

- 1) Su analizi için genel kriter: PH > 6,5; Cl < 150 mg/kg, Cl < 0,6 mg/kg.
Bronz parçalar içeren pompalar için kriter: Amonyak (NH) < 5 mg/kg,
Hidrojen sülfat'tan (H S); arındırılmış olmalıdır. Eğer limitler aşıyor ise lütfen KSB Ofislerine başvurunuz.
- 2) 25°C'deki iletkenlik <250 uS/cm. SiO (Silikat) içeriği <10 mg/l
- 3) 25°C'deki iletkenlik : 100 ile 800 uS/cm
- 4) % 20 ile % 50 arasında
- 5) Ultra saf su değil! 25°C'deki iletkenlik < 800 uS/cm

Beta 32-125

2900 d/dak

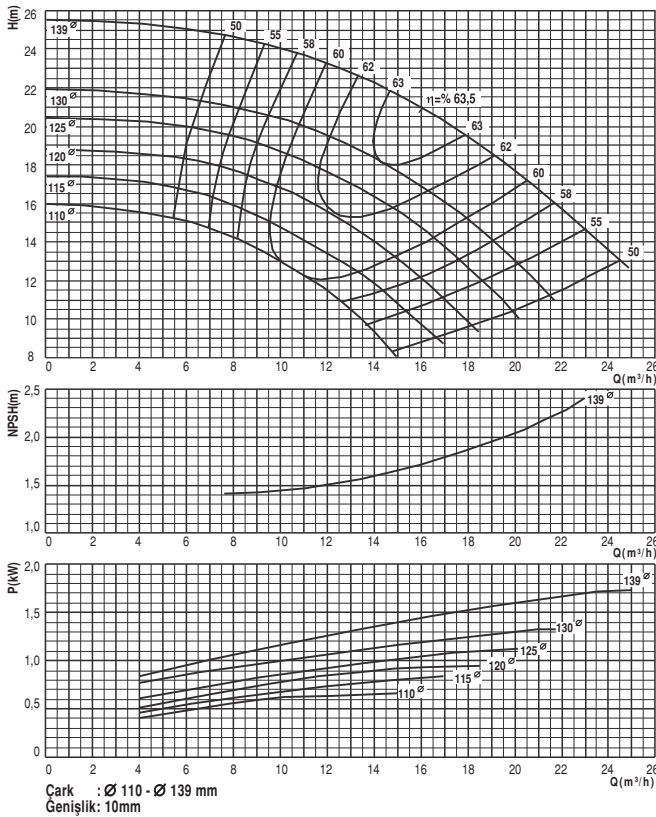

Beta 32-160

2900 d/dak

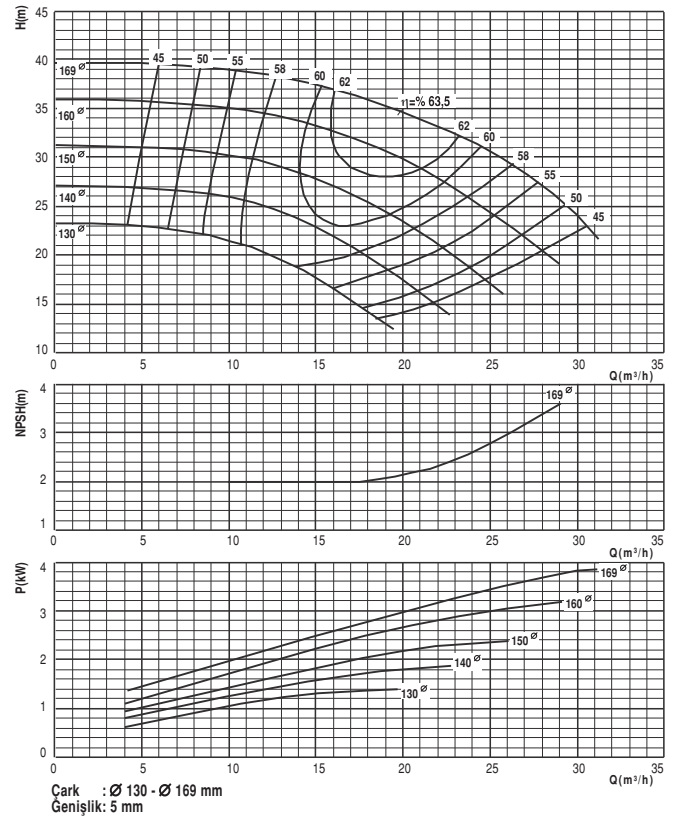

Beta 32-200

2900 d/dak

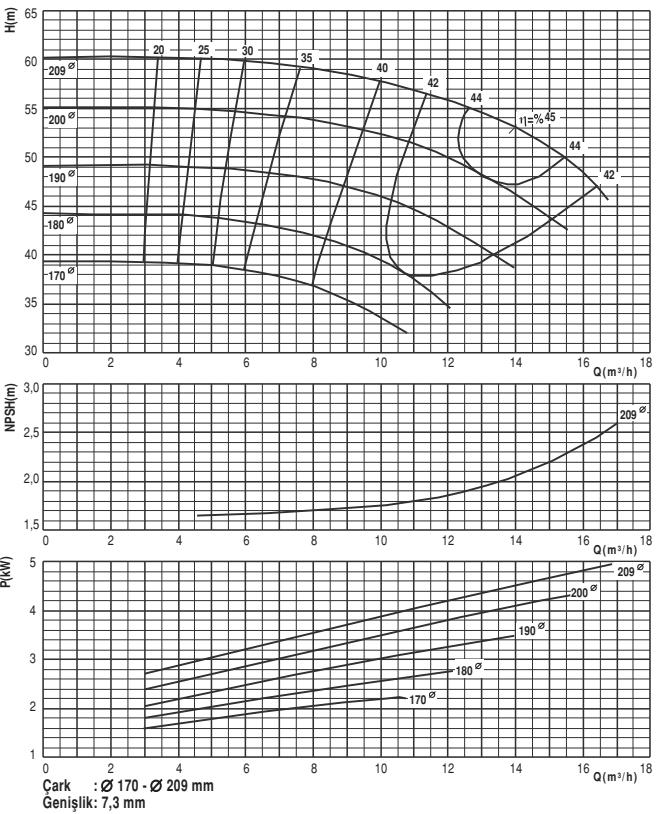

Beta 32-250

2900 d/dak

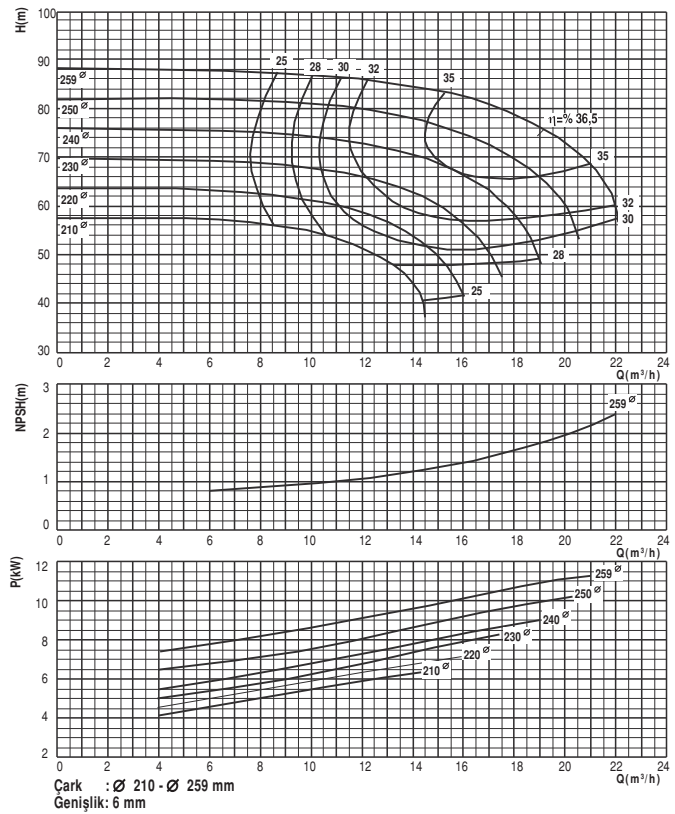

Beta 40-125

2900 d/dak

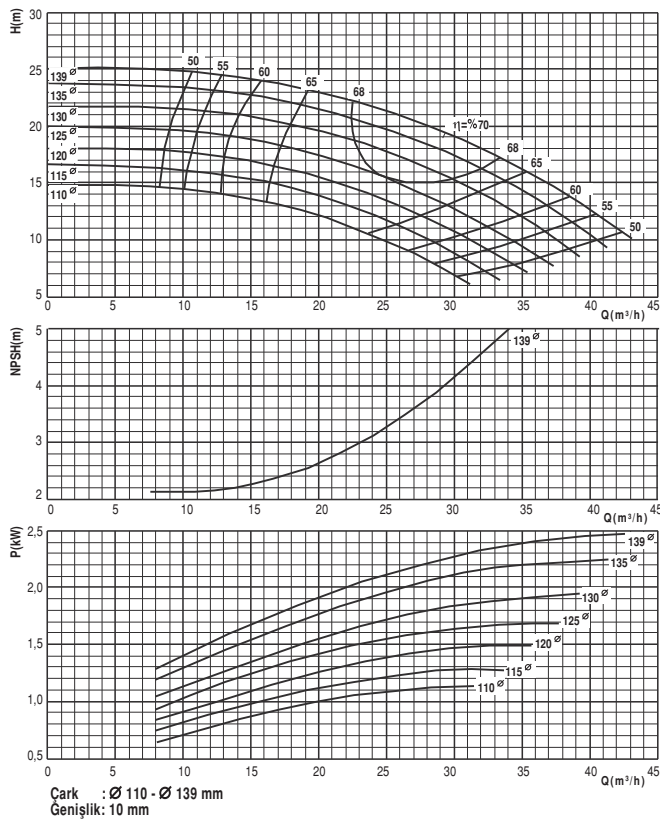

Beta 40-160

2900 d/dak

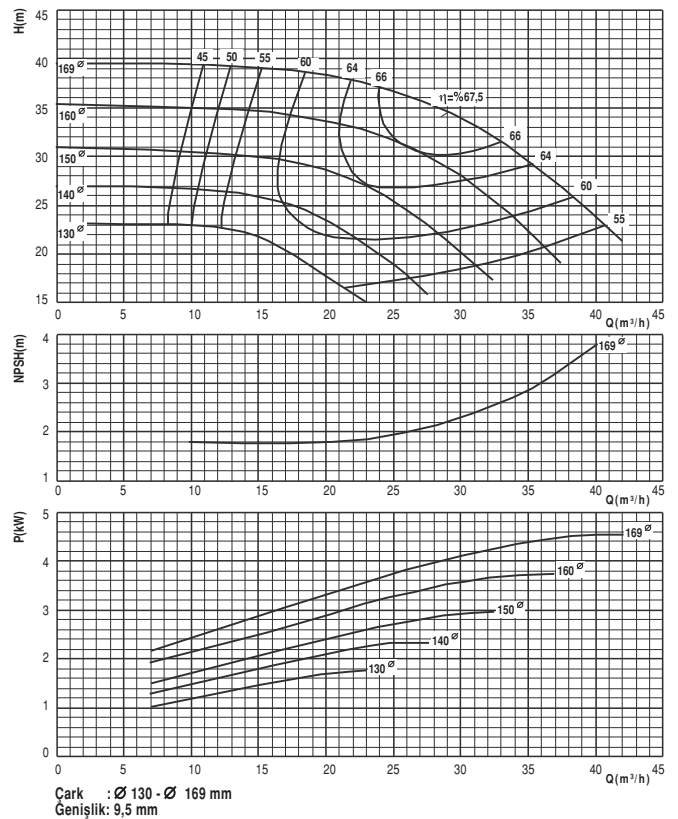

Beta 40-200

2900 d/dak

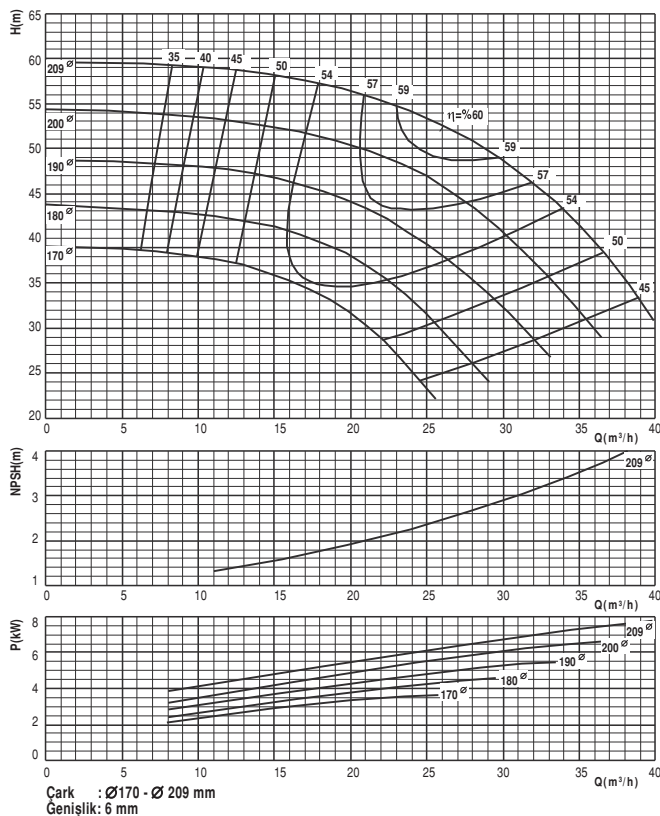

Beta 40-250

2900 d/dak

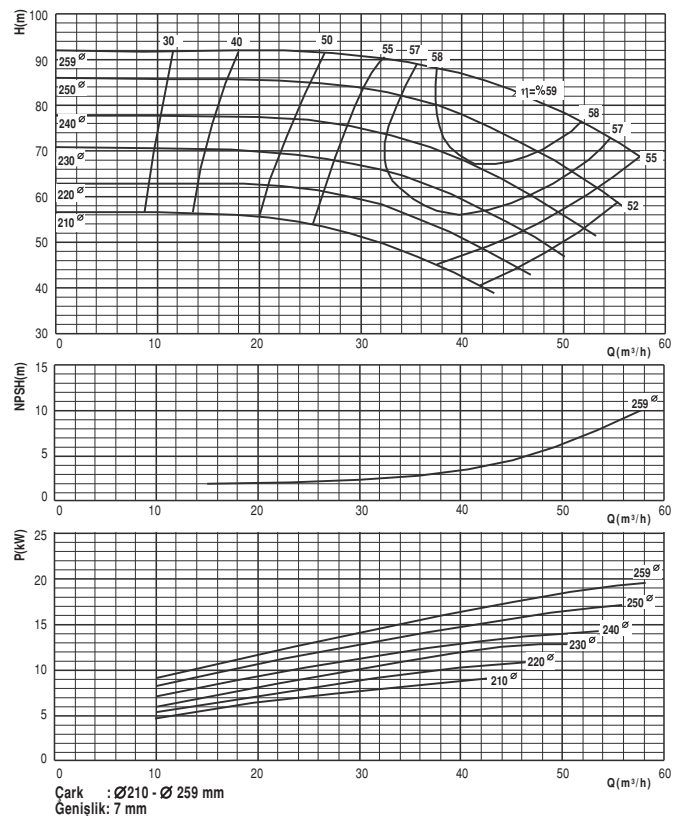

Beta 50-125

2900 d/dak

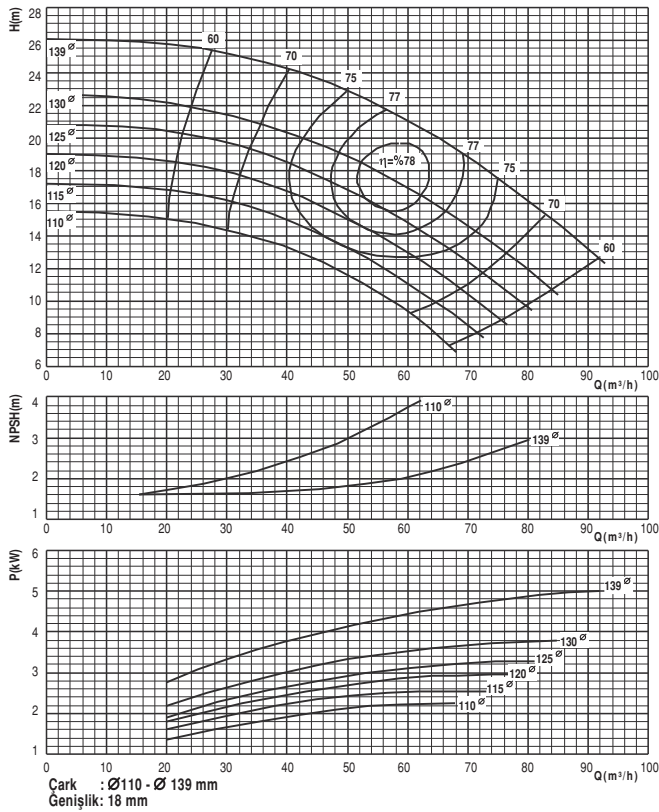

Beta 50-160

2900 d/dak

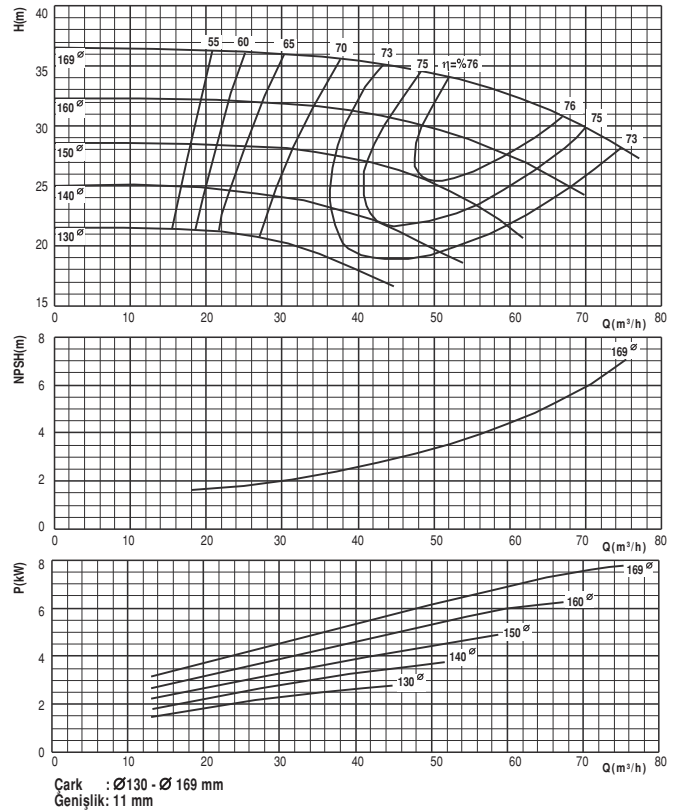

Beta 50-200

2900 d/dak

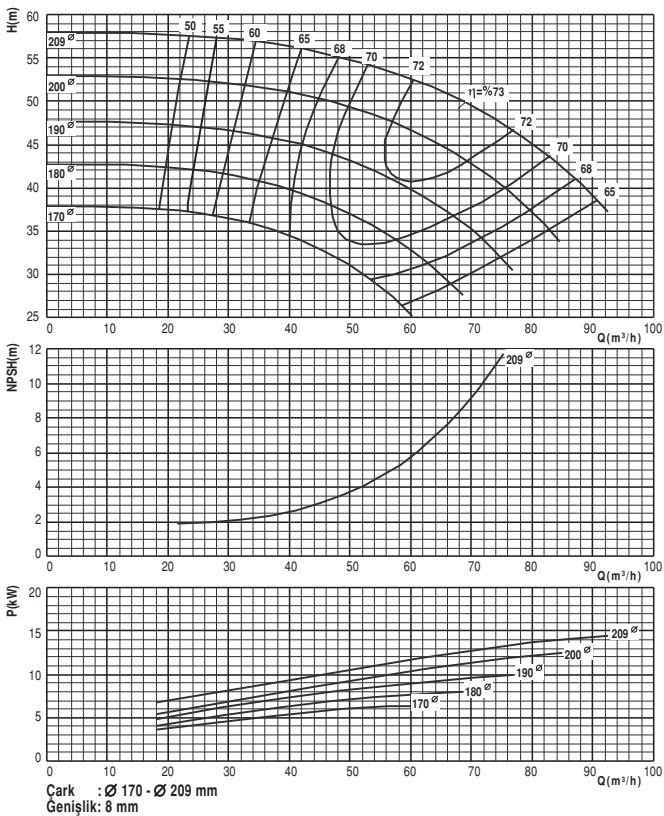

Beta 50-250

2900 d/dak

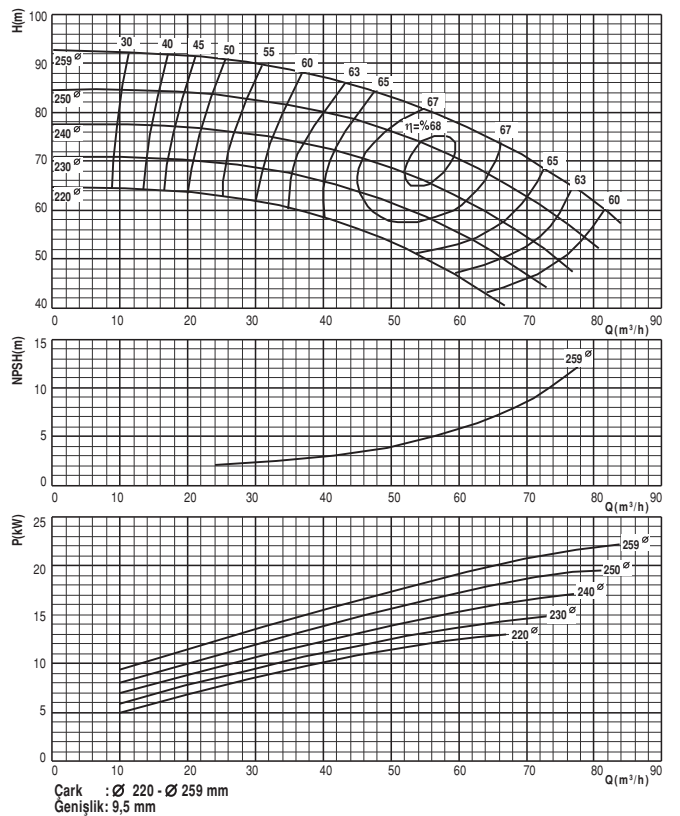

Beta 65-125

2900 d/dak

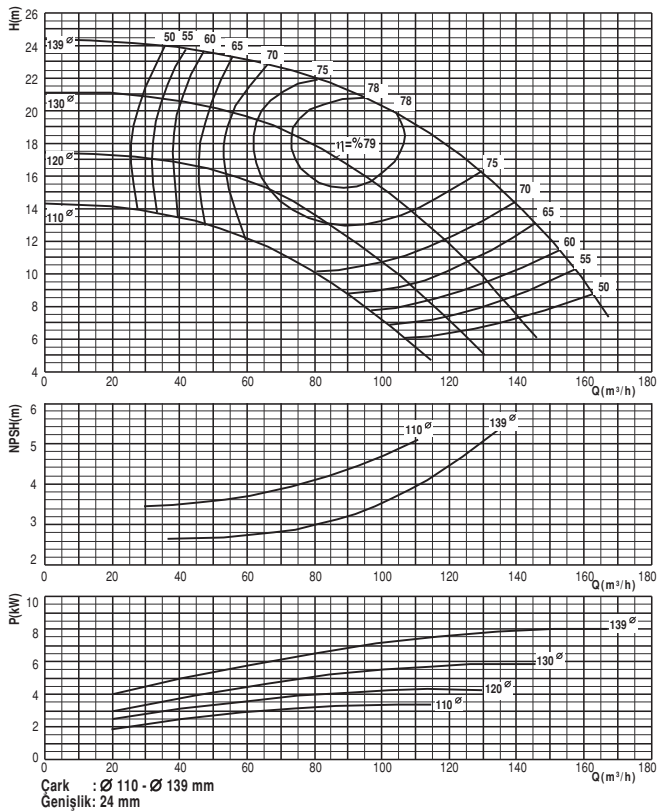

Beta 65-160

2900 d/dak

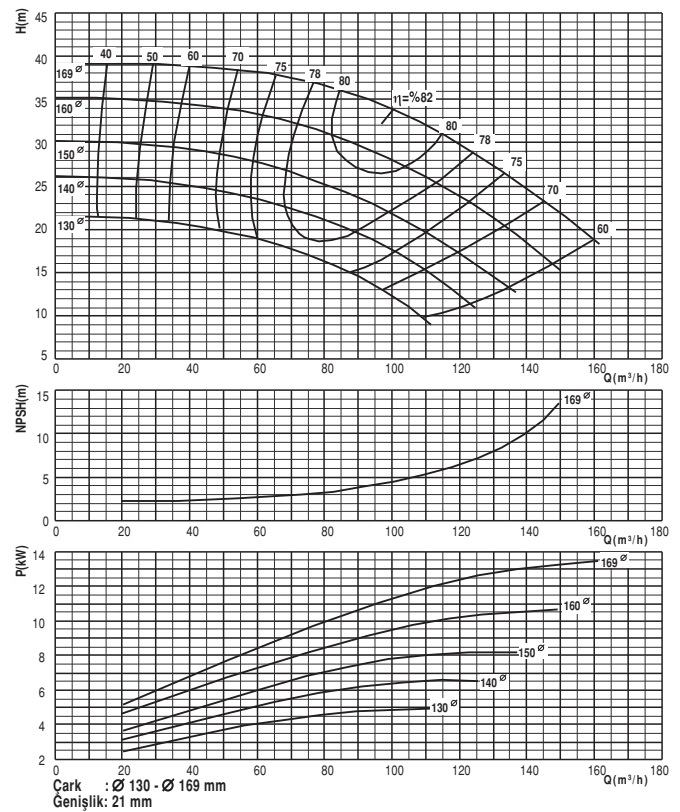

Beta 65-200

2900 d/dak

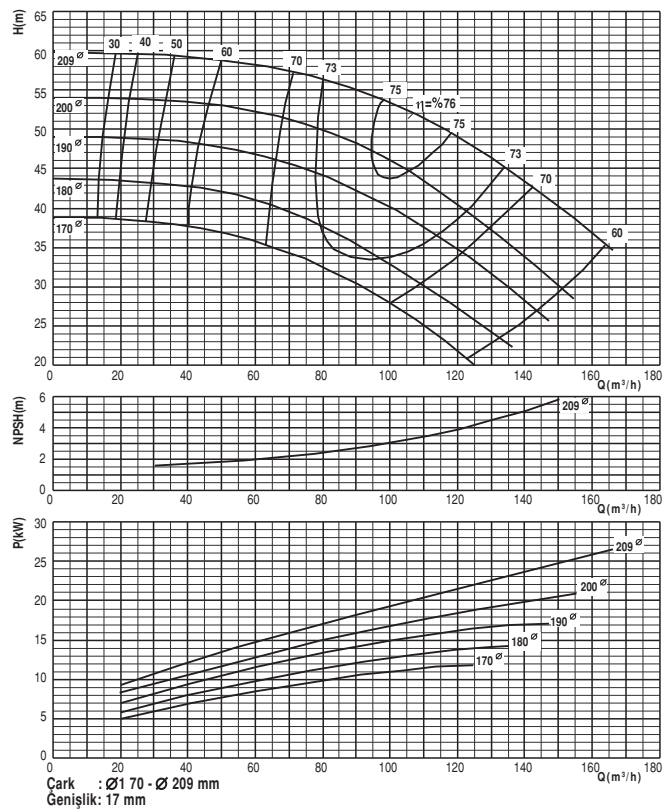

Beta 65-250

2900 d/dak

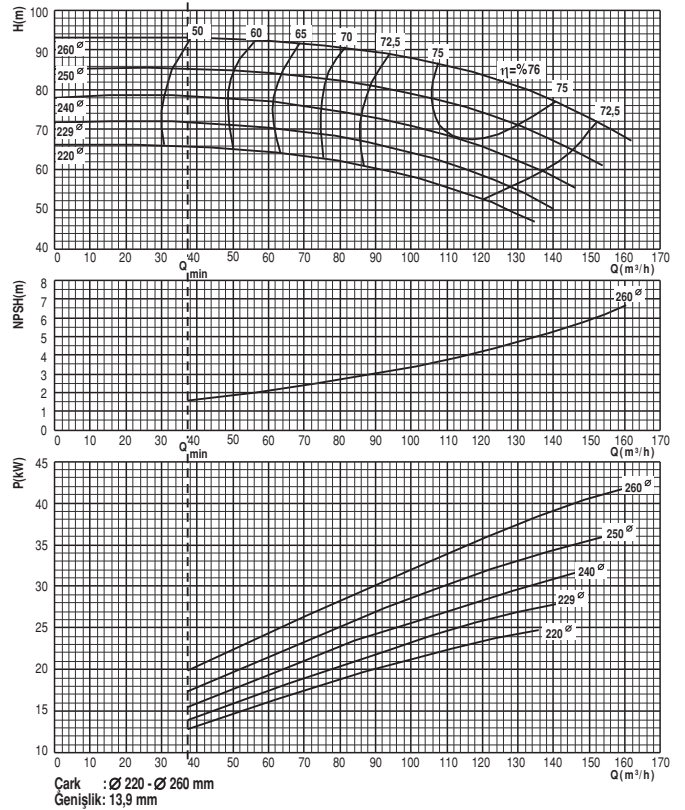

Beta 80-160

2900 d/dak

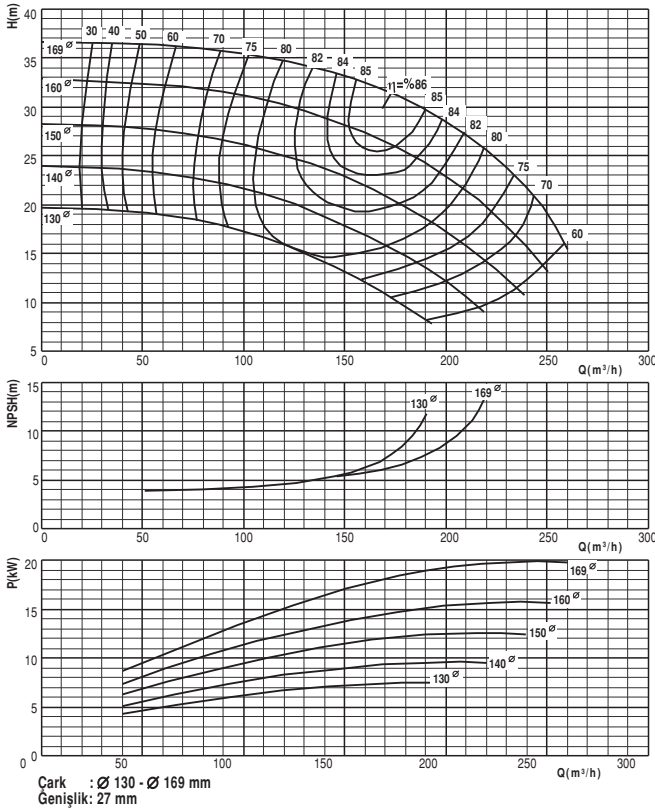

Mega 80-200

2900 d/dak

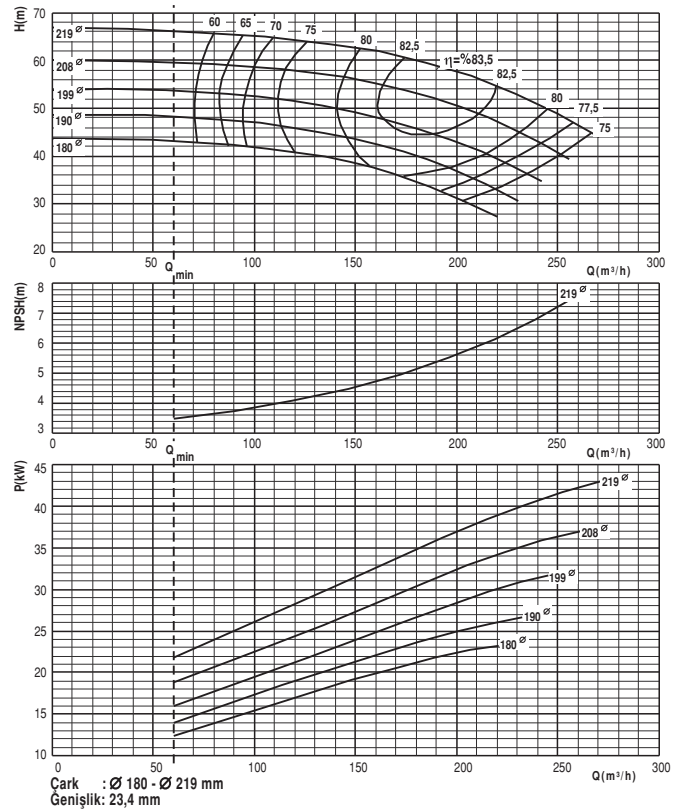

Mega 80-250

2900 d/dak

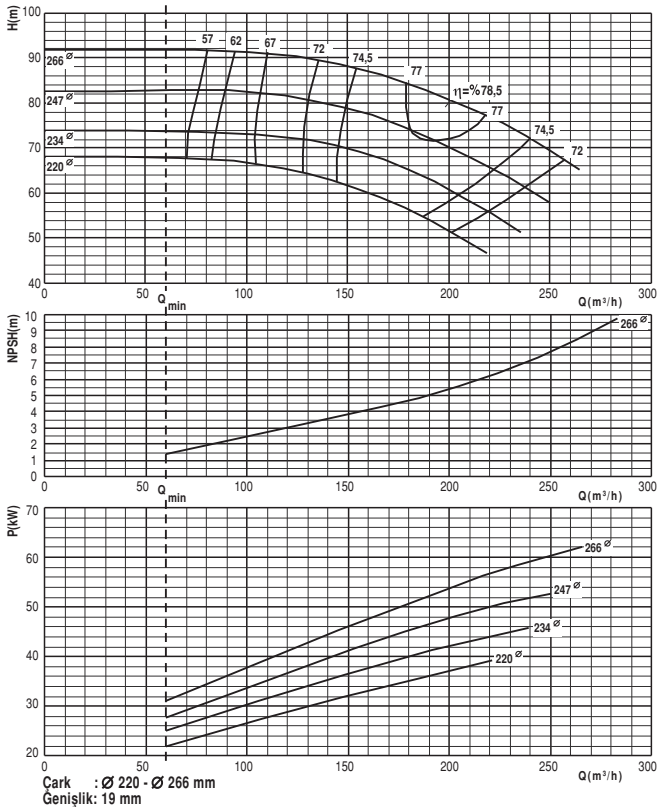

Mega 100-160

2900 d/dak

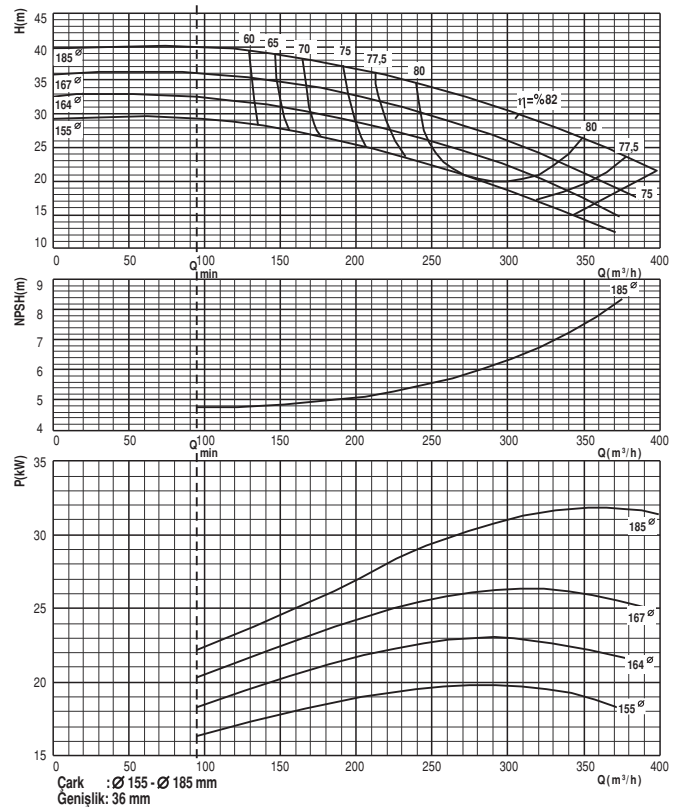

Mega 100-200

2900 d/dak

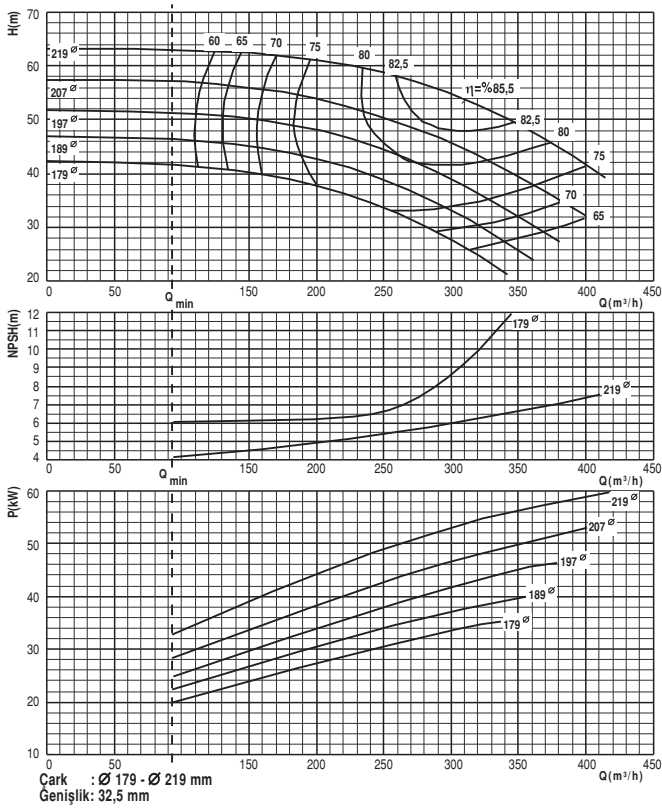

Mega 100-250

2900 d/dak

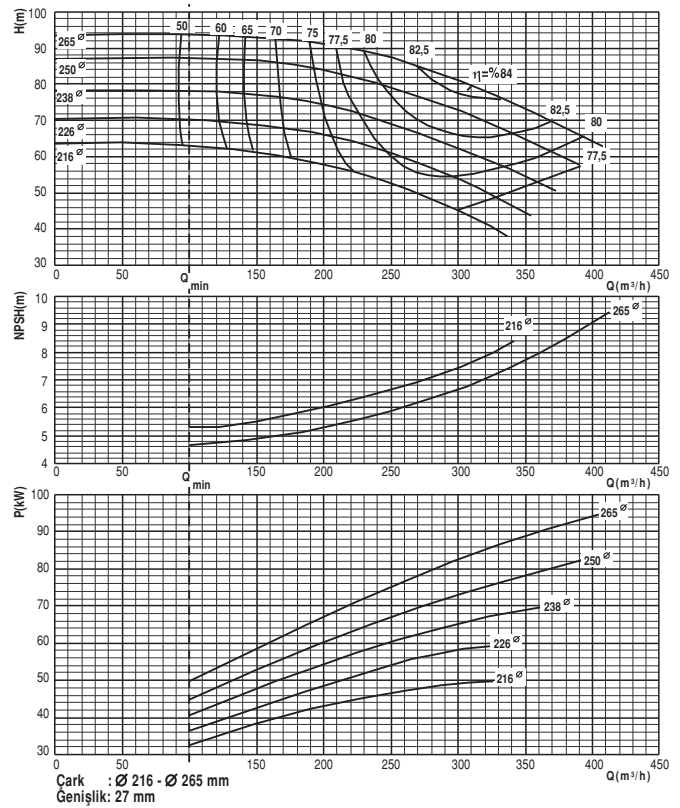

Mega 125-200

2900 d/dak

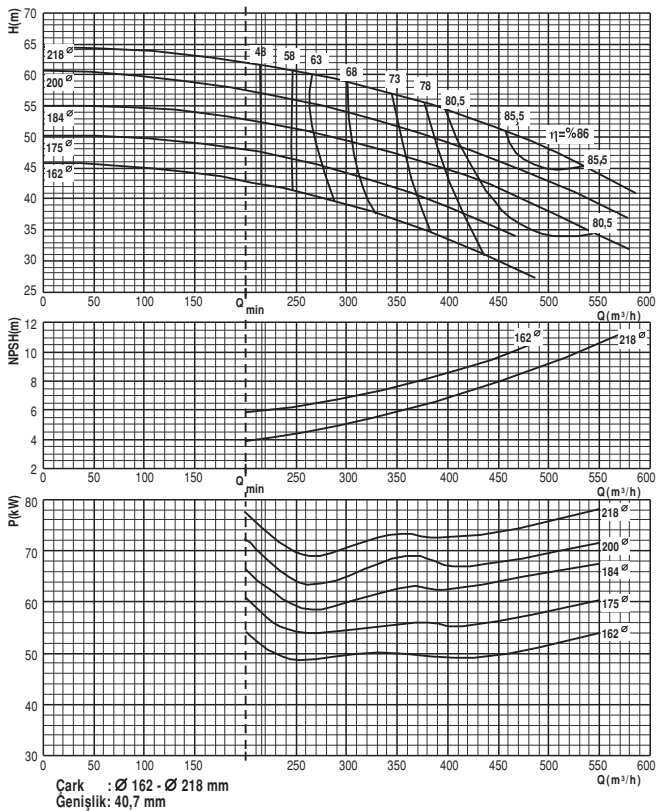

Beta 32-125

1450 d/dak

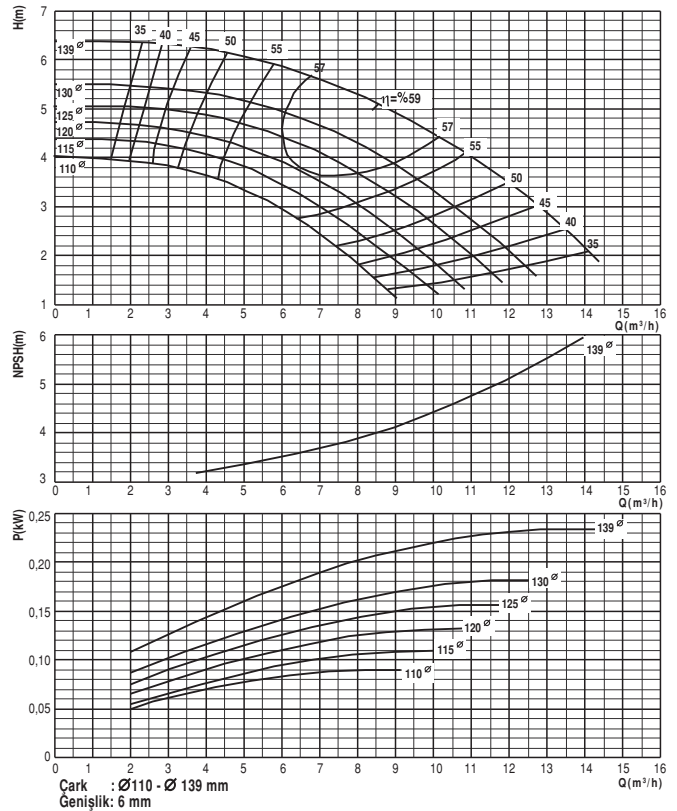

Beta 32-160

1450 d/dak

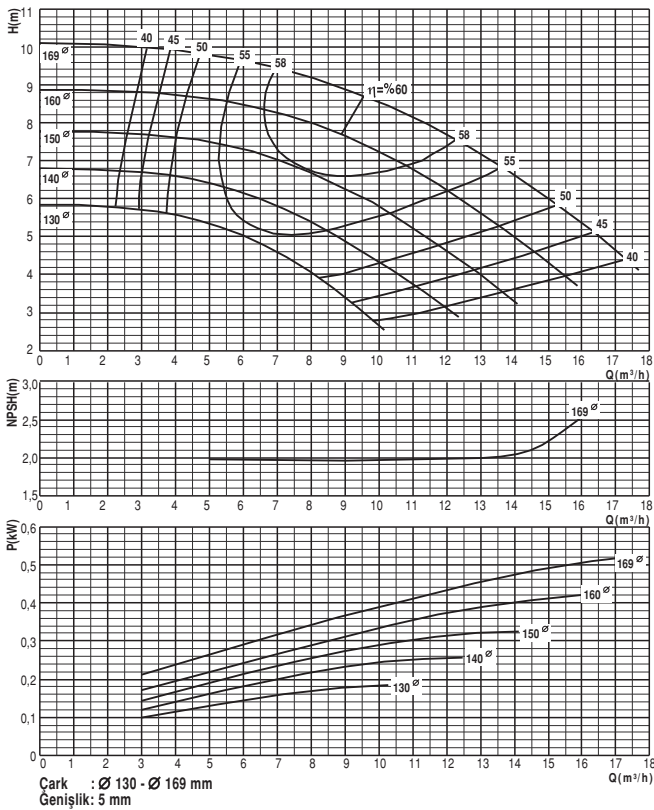

Beta 32-200

1450 d/dak

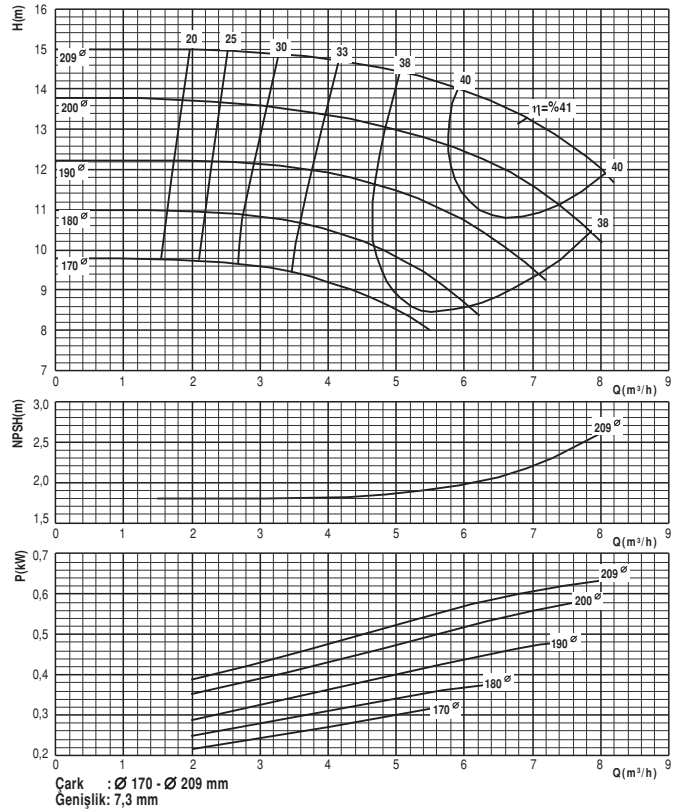

Beta 32-250

1450 d/dak

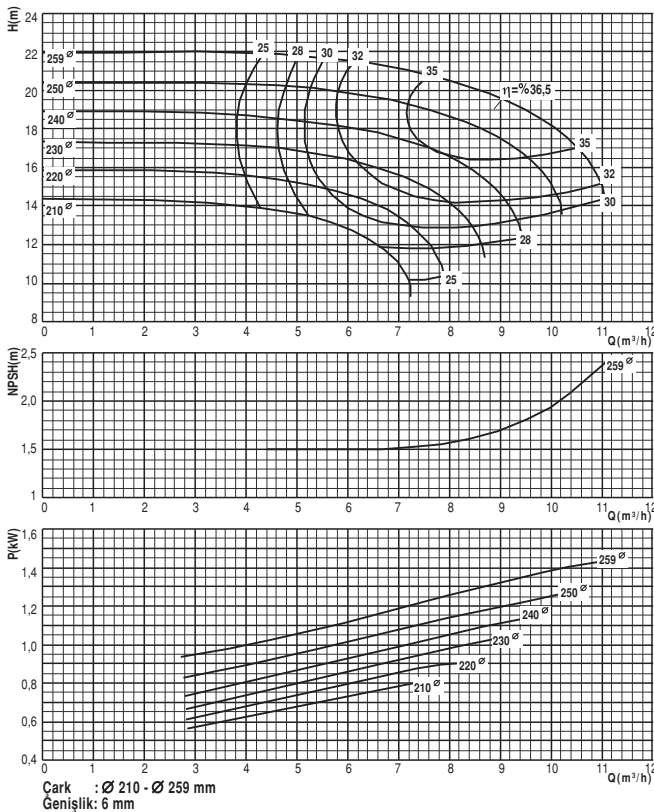

Beta 40-125

1450 d/dak

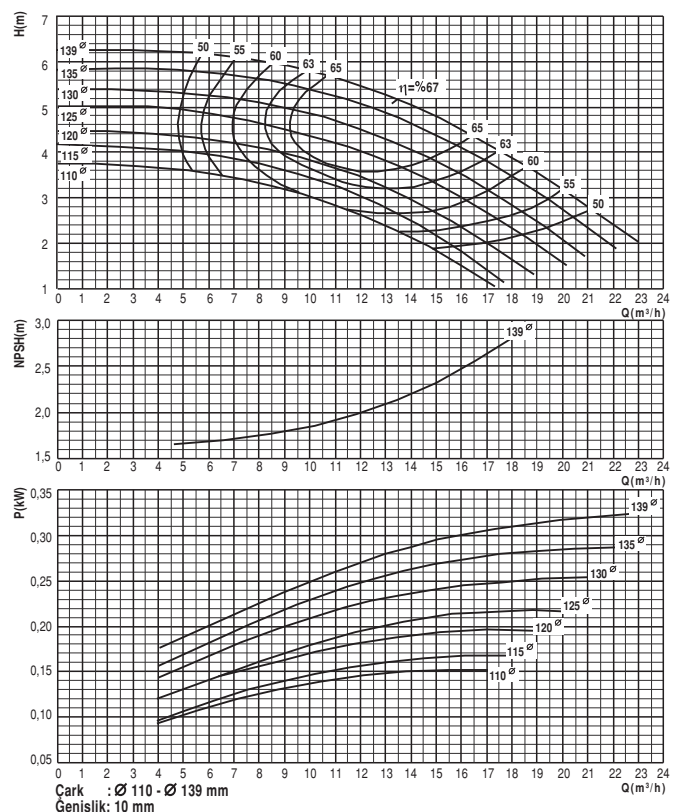

Beta 40-160

1450 d/dak

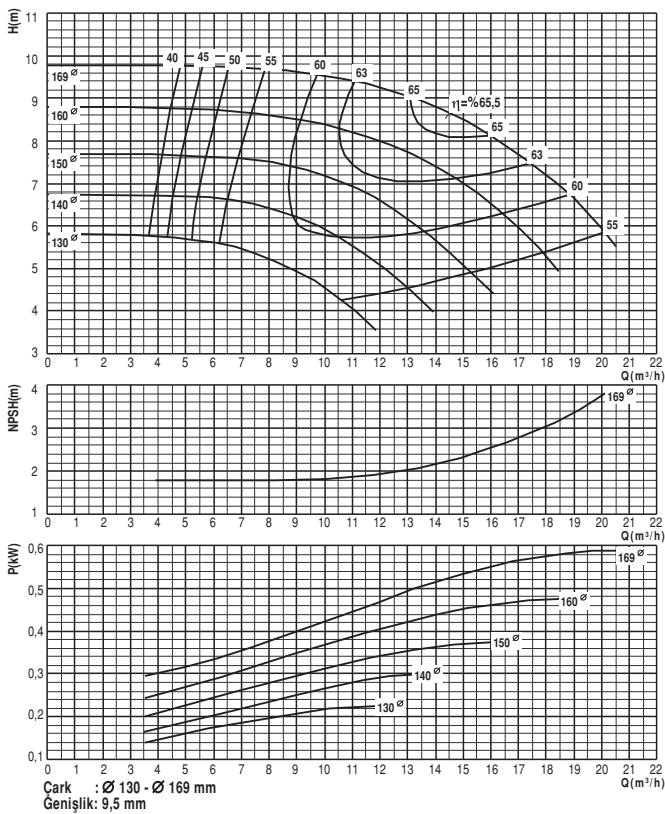

Beta 40-200

1450 d/dak

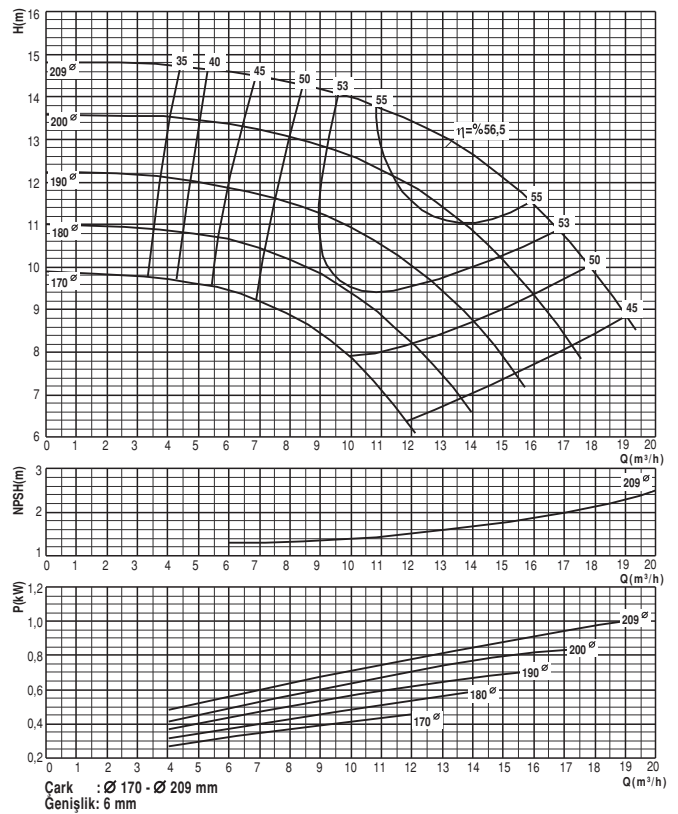

Beta 40-250

1450 d/dak

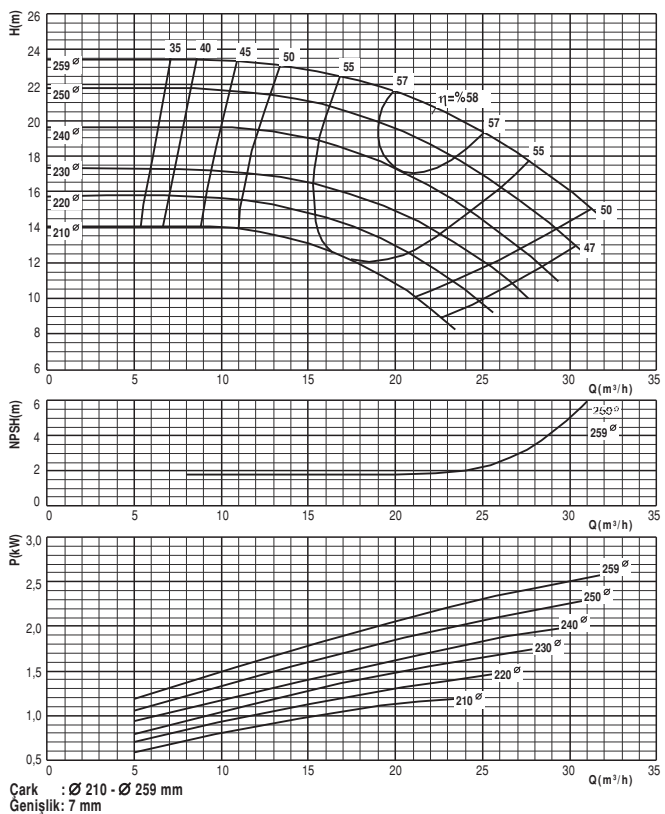

Beta 40-315

1450 d/dak

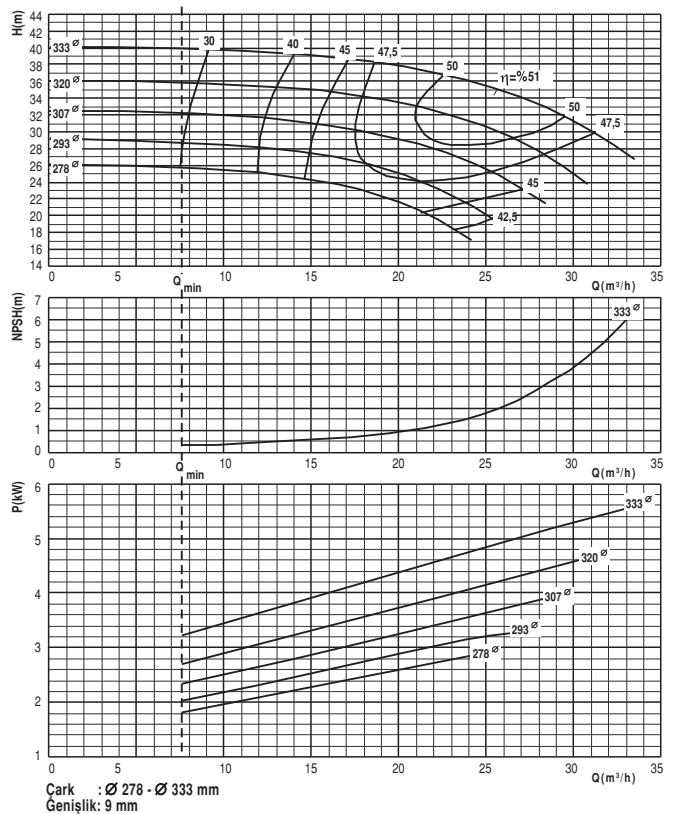

Beta 50-125

1450 d/dak

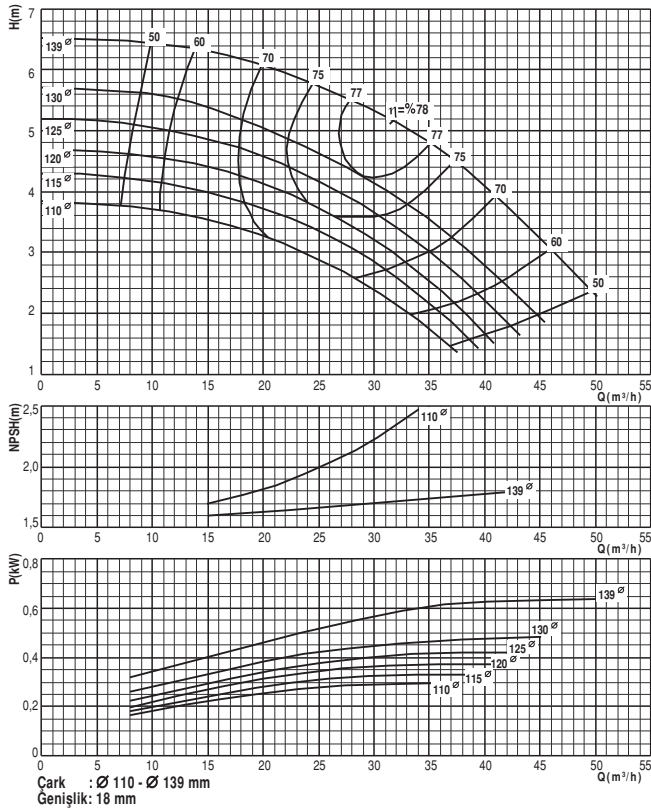

Beta 50-160

1450 d/dak

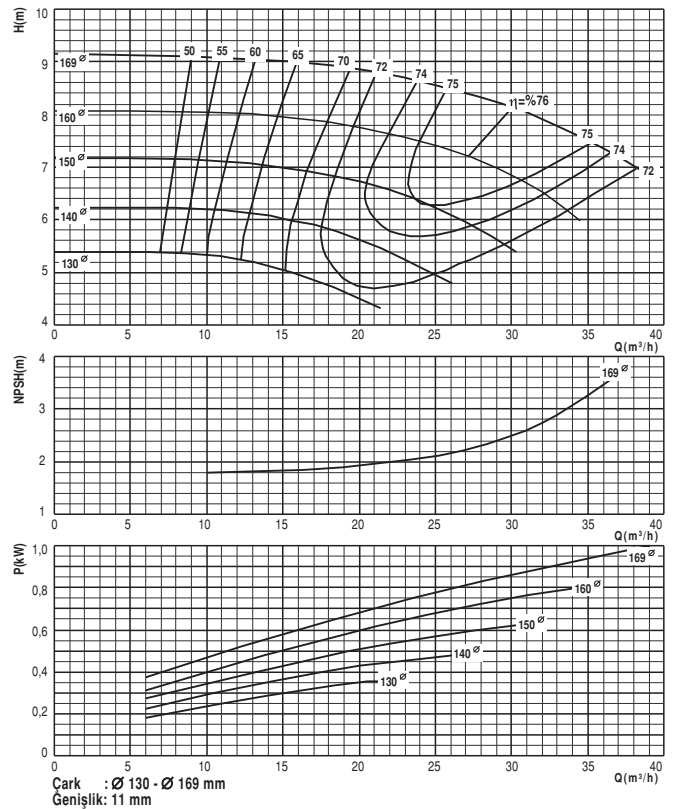

Beta 50-200

1450 d/dak

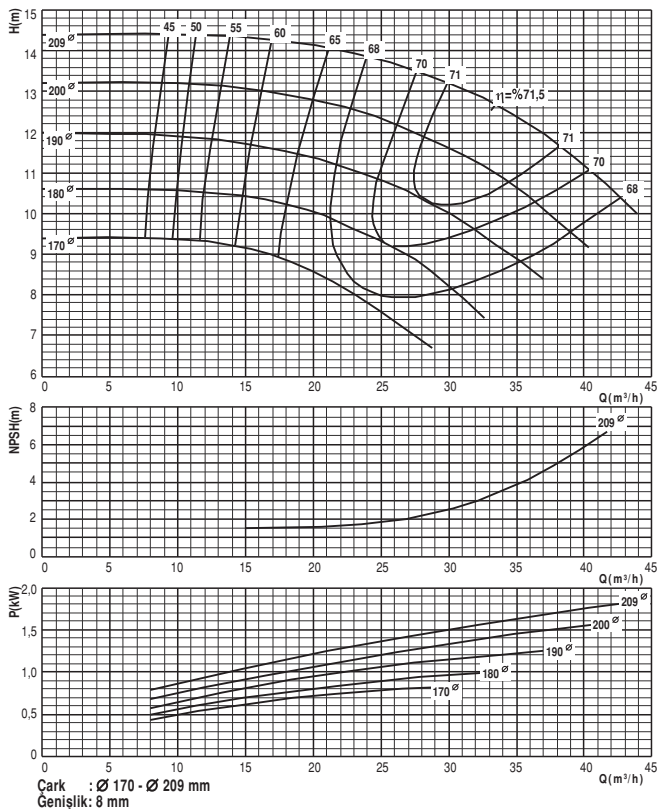

Beta 50-250

1450 d/dak

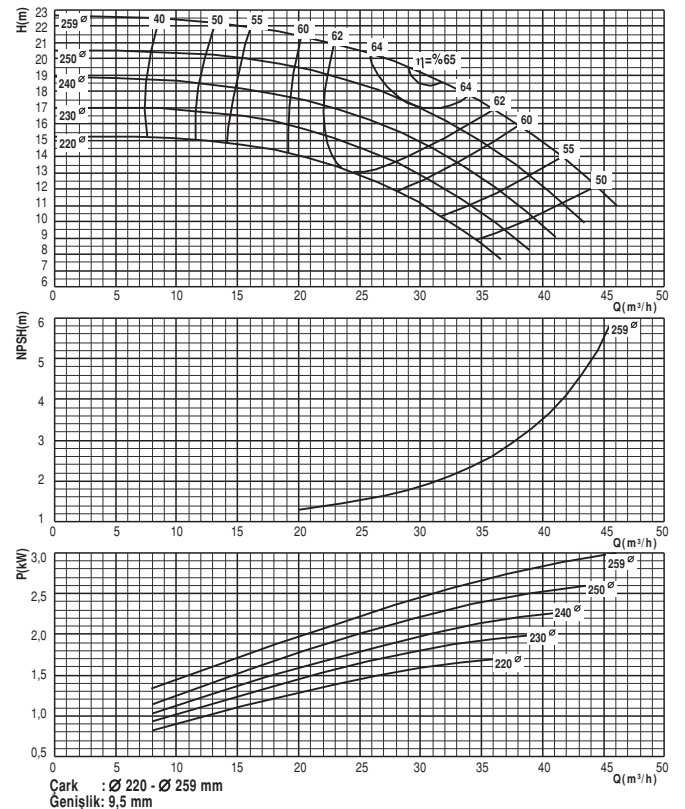

Beta 50-315

1450 d/dak

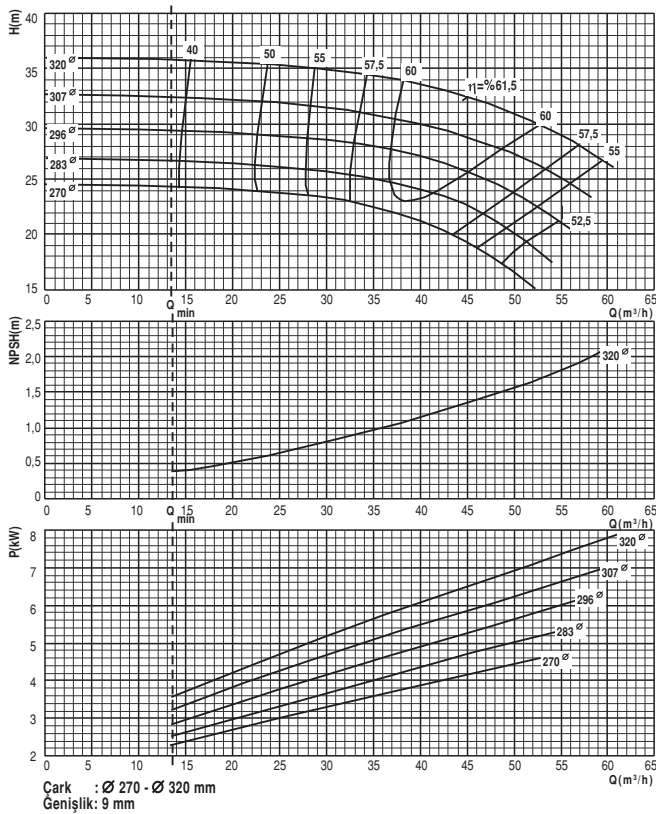

Beta 65-125

1450 d/dak

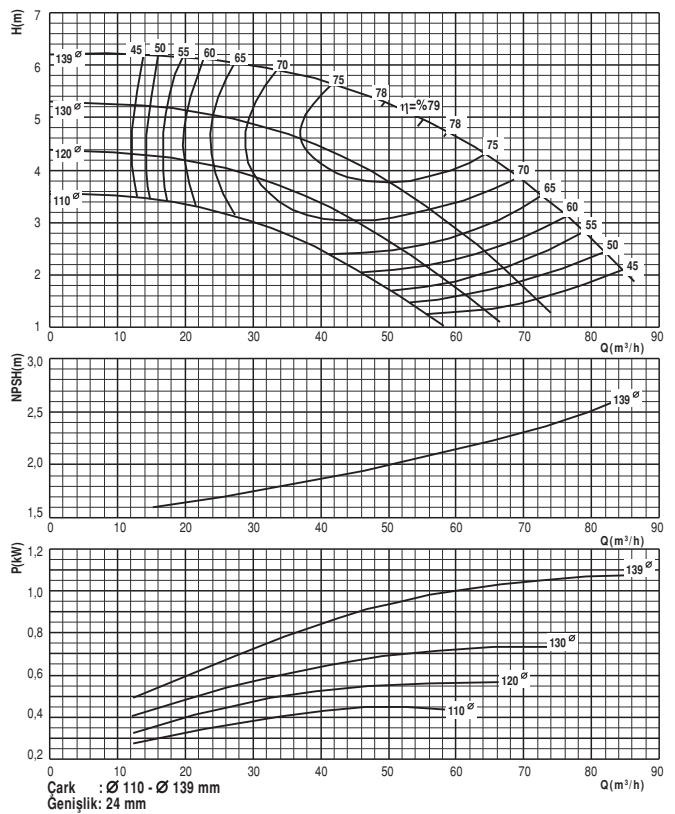

Beta 65-160

1450 1d/dak

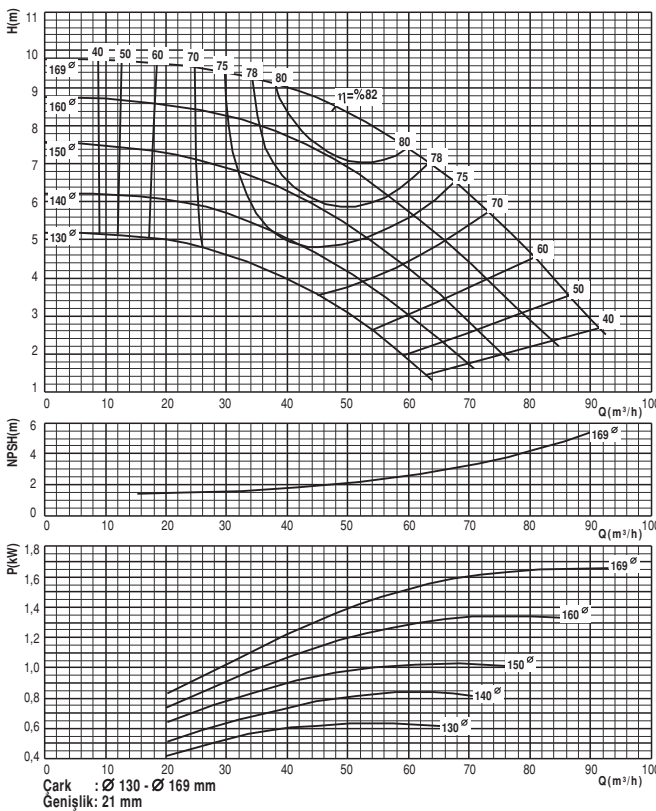

Beta 65-200

1450 d/dak

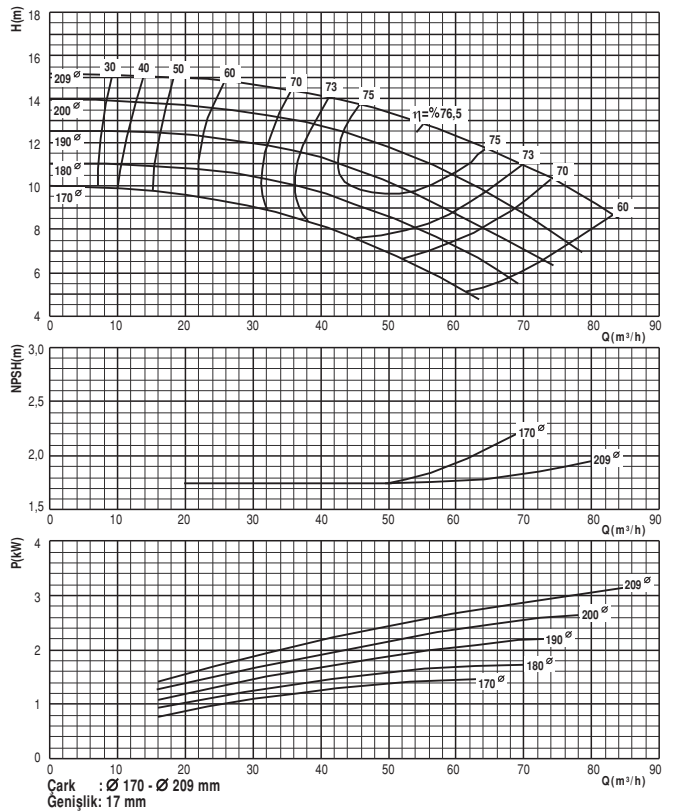

Beta 65-250

1450 d/dak

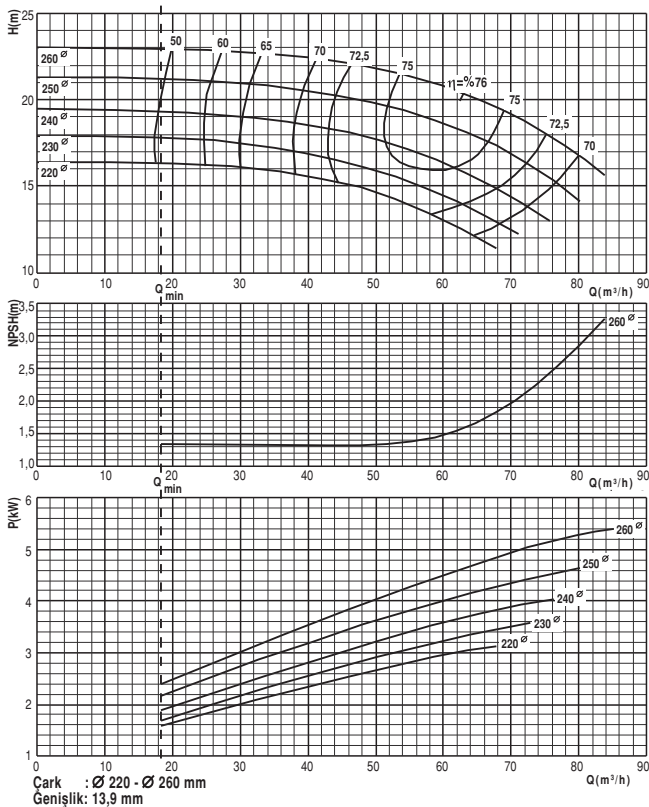

Beta 65-315

1450 d/dak

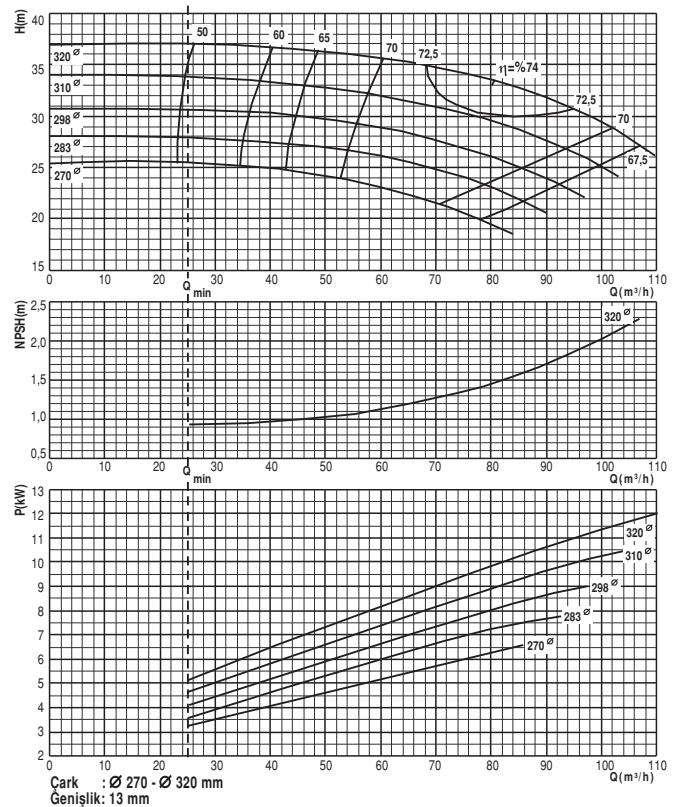

Beta 80-160

1450 d/dak

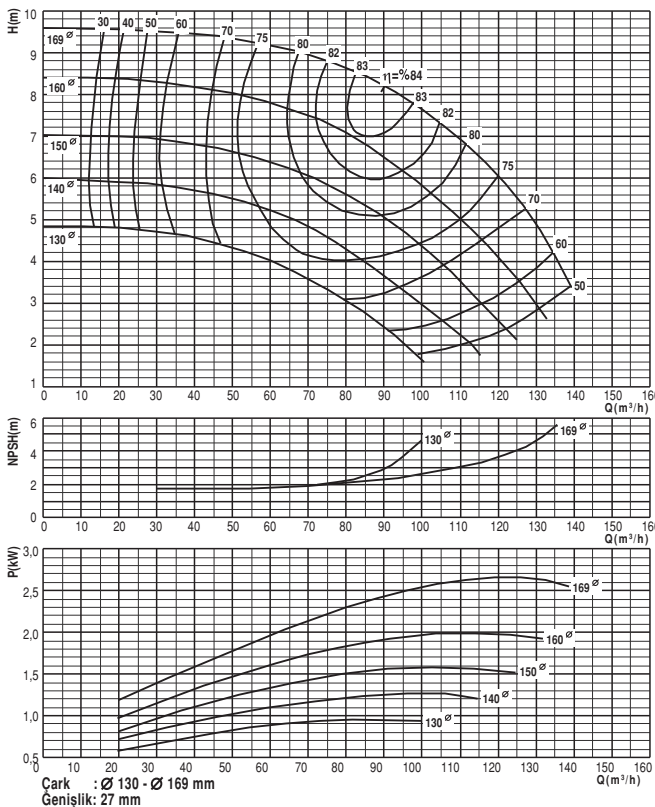

Mega 80-200

1450 d/dak

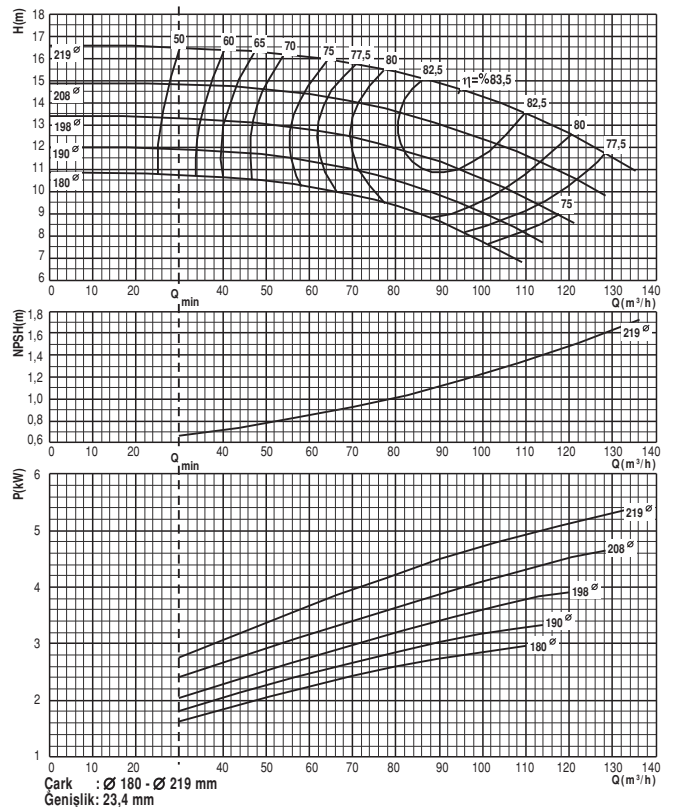

Mega 80-250

1450 d/dak

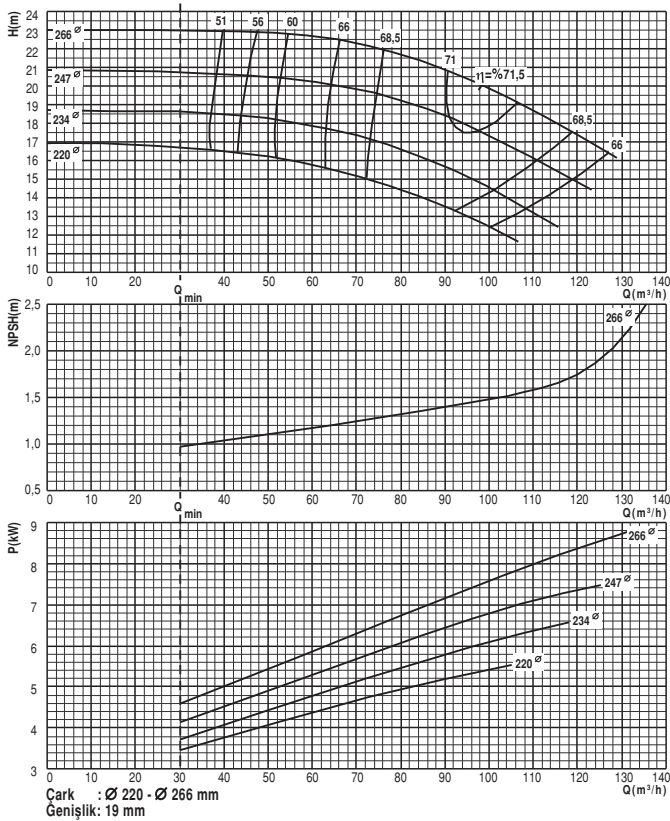

Beta 80-315

1450 d/dak

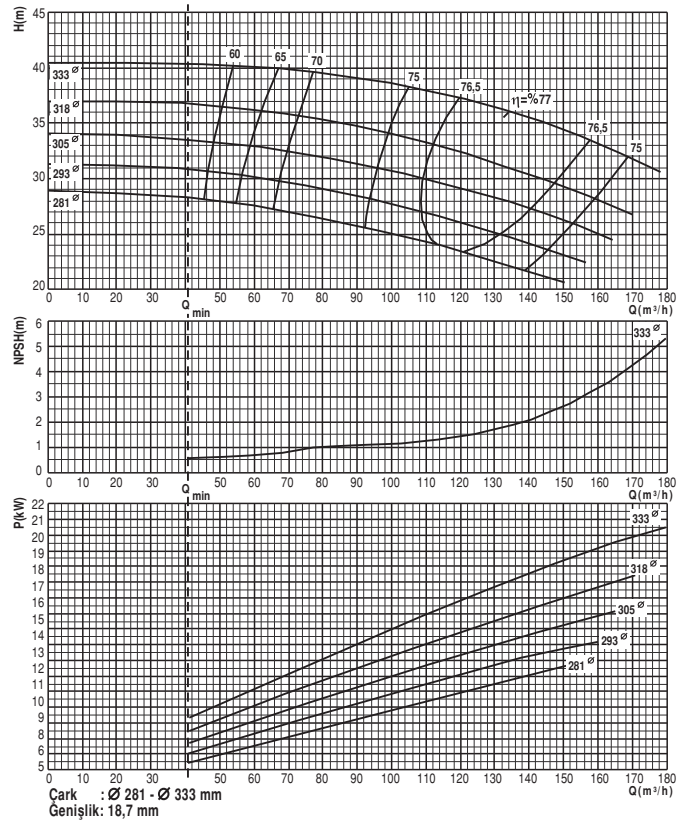

Mega 80-400

1450 d/dak

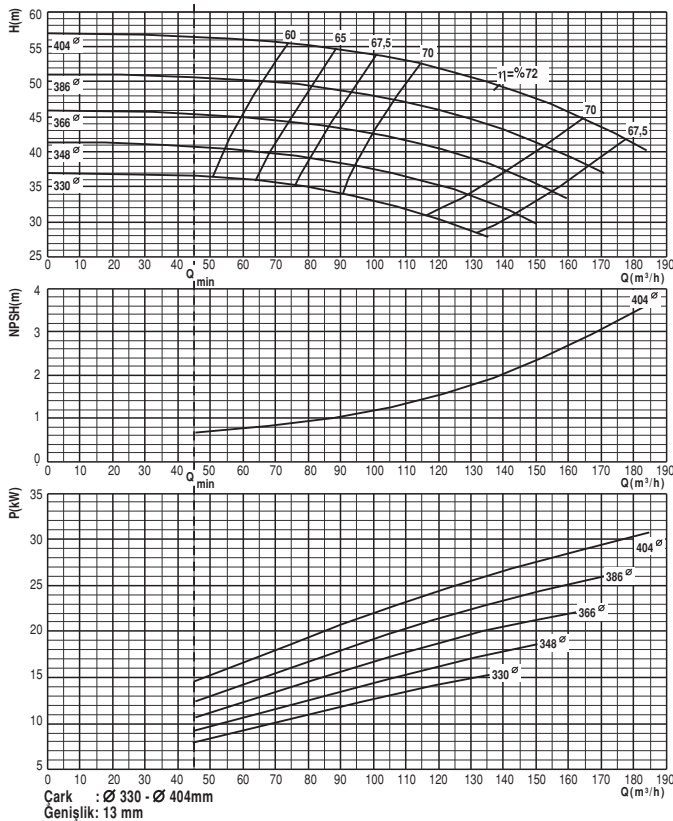

Mega 100-160

1450 d/dak

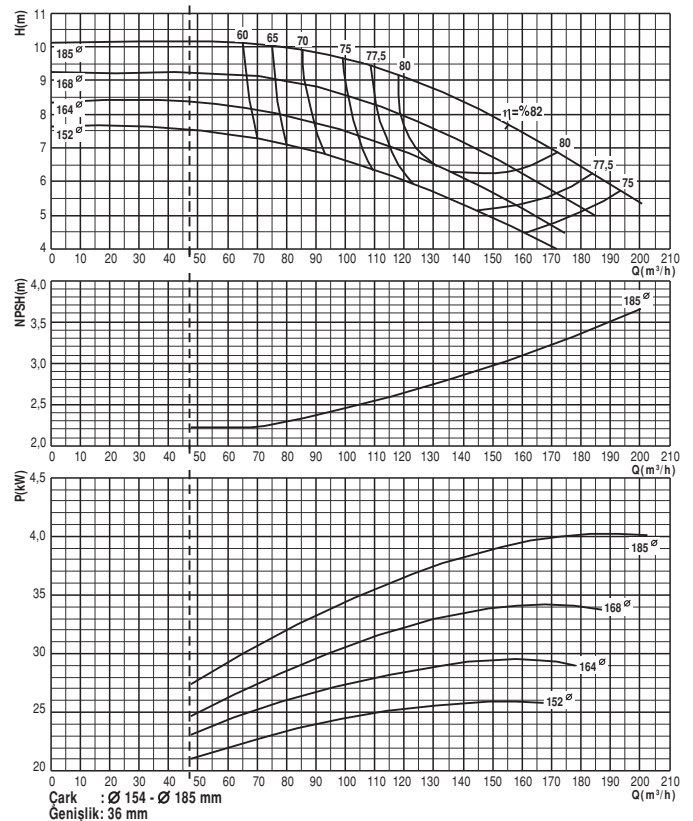

Mega 100-200

1450 d/dak

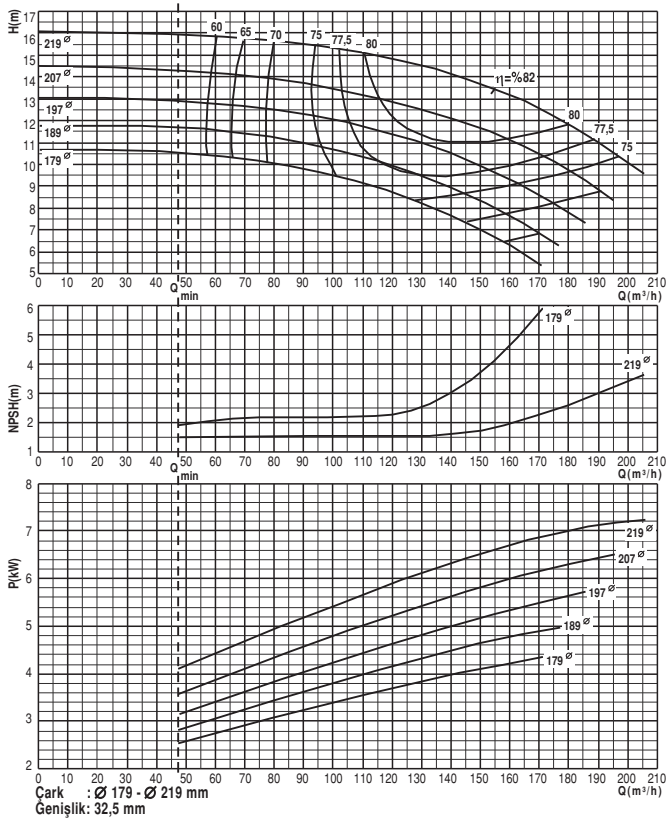

Mega 100-250

1450 d/dak

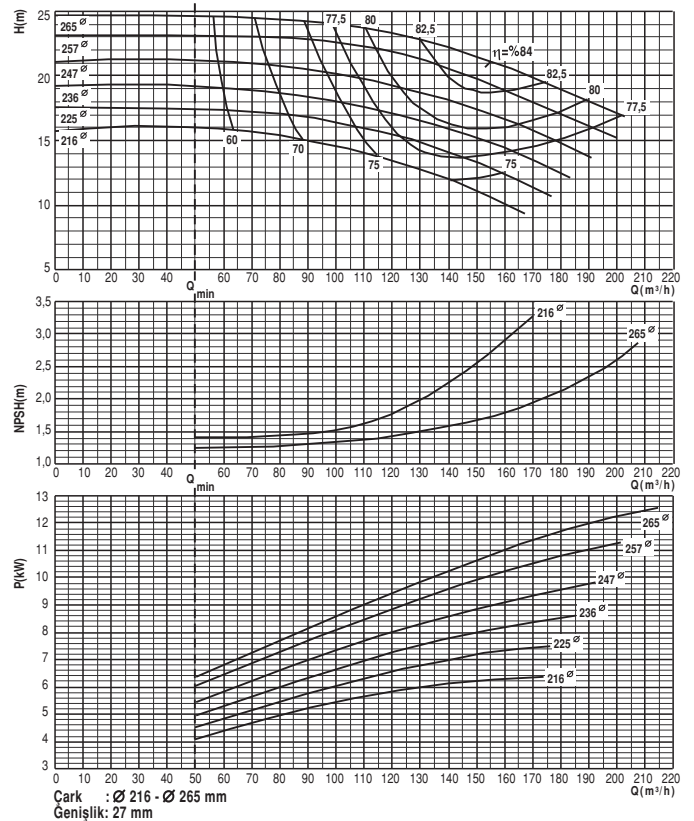

Mega 100-315

1450 d/dak

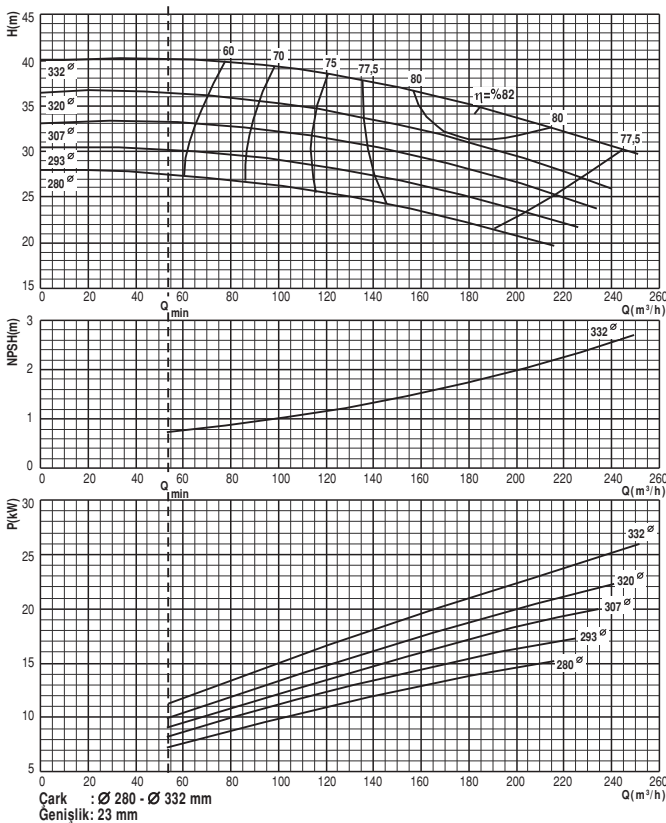

Mega 100-400

1450 d/dak

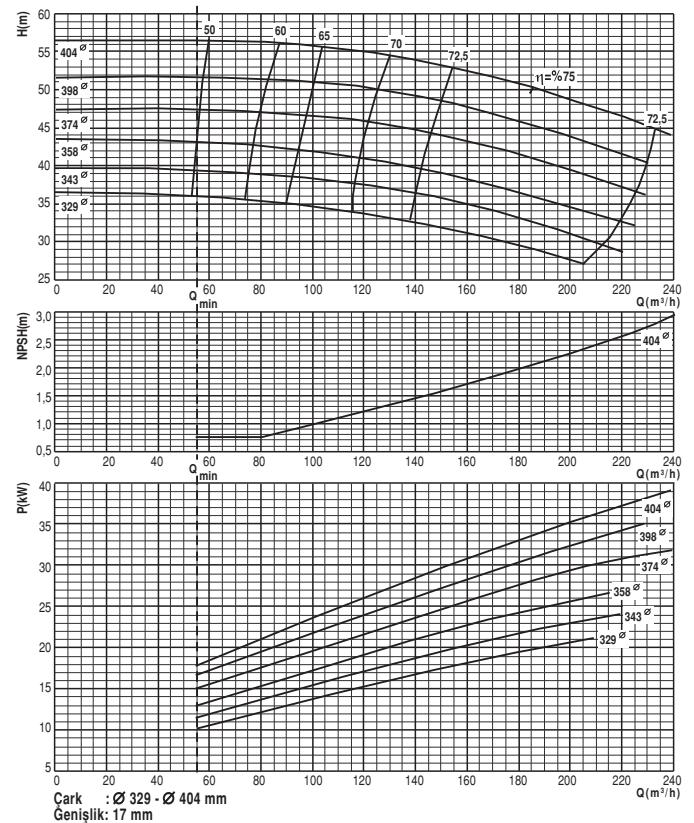

Mega 125-200

1450 d/dak

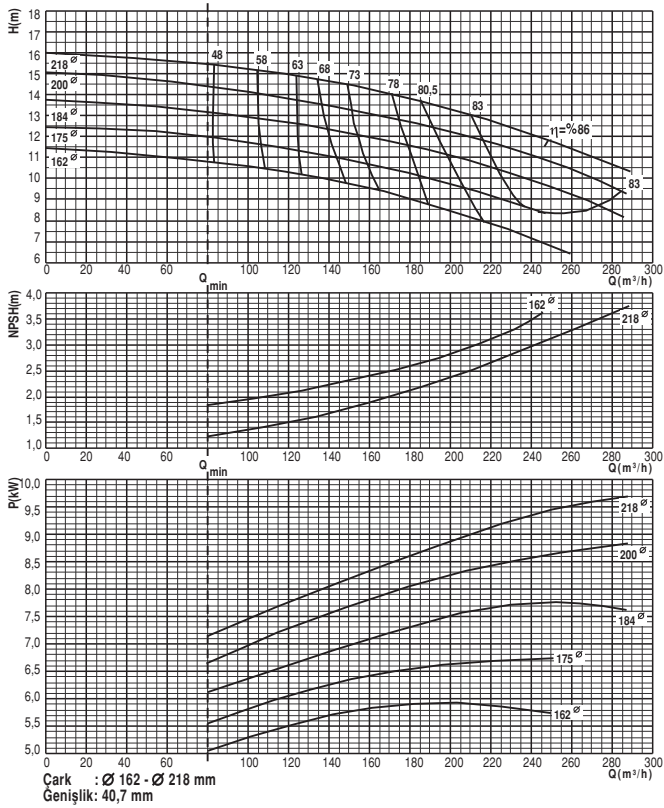

Mega 125-250

1450 d/dak

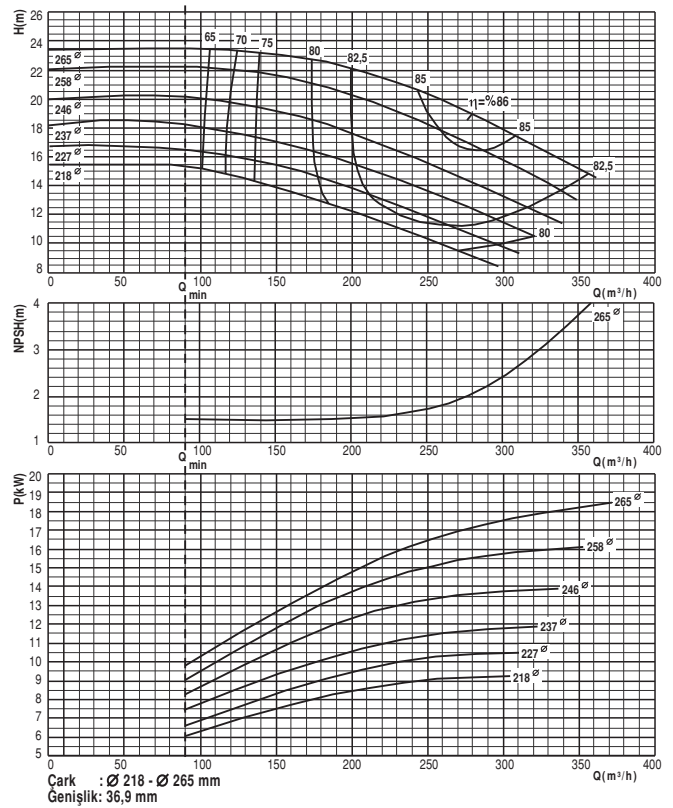

Mega 125-315

1450 d/dak

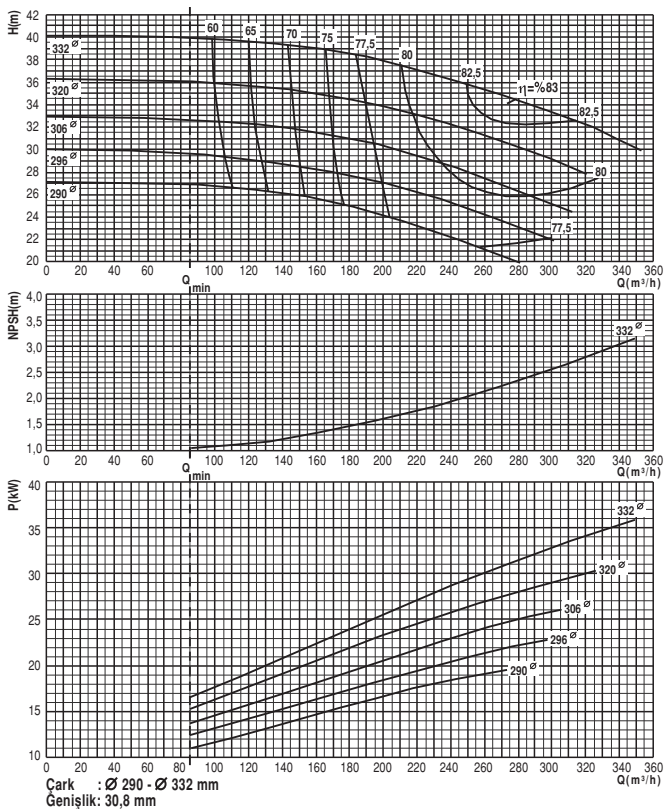

Mega 125-400

1450 d/dak

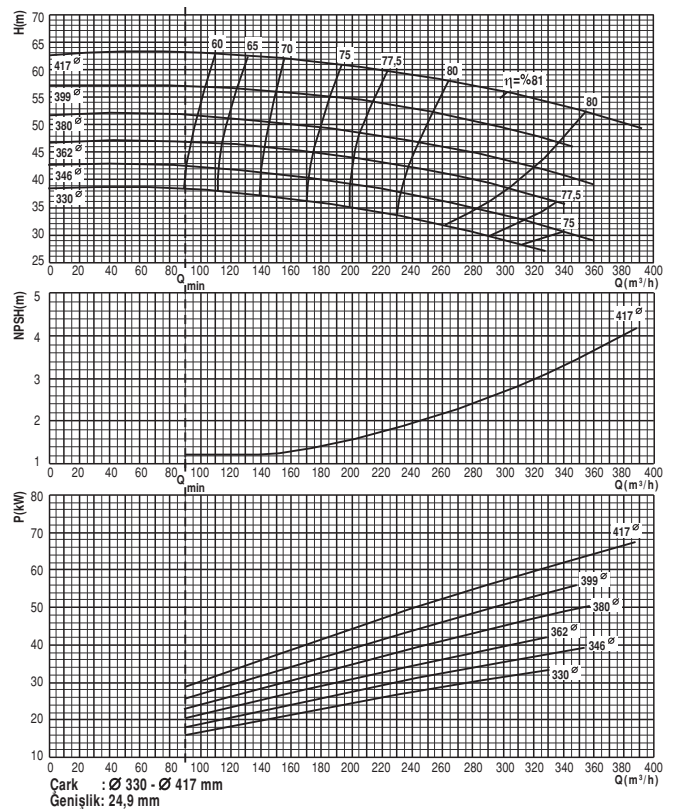

Mega 150-200

1450 d/dak

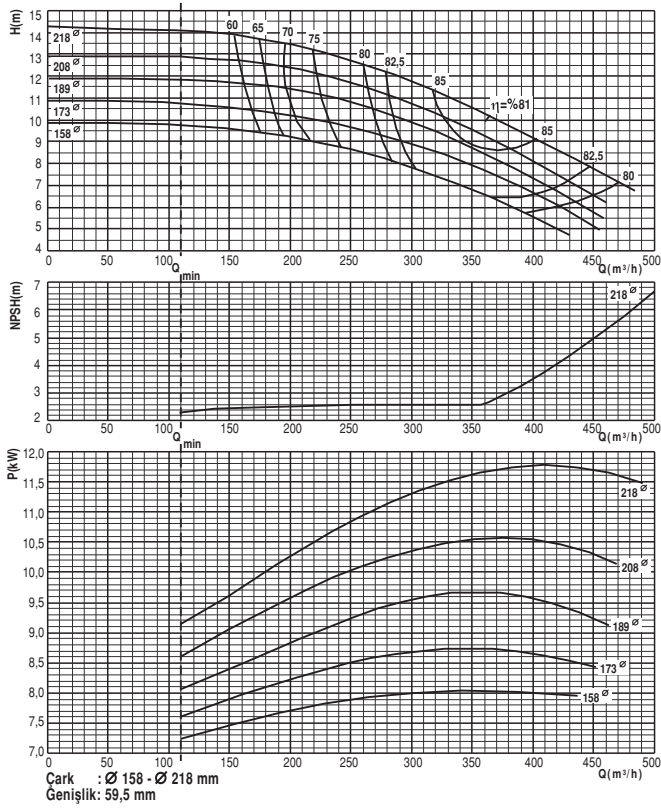

Mega 150-250

1450 d/dak

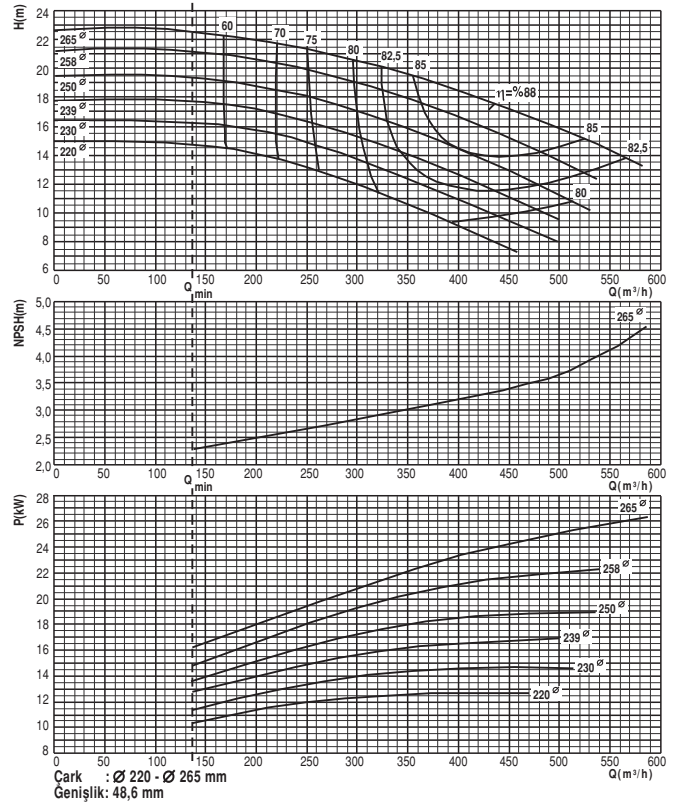

Mega 150-315

1450 d/dak

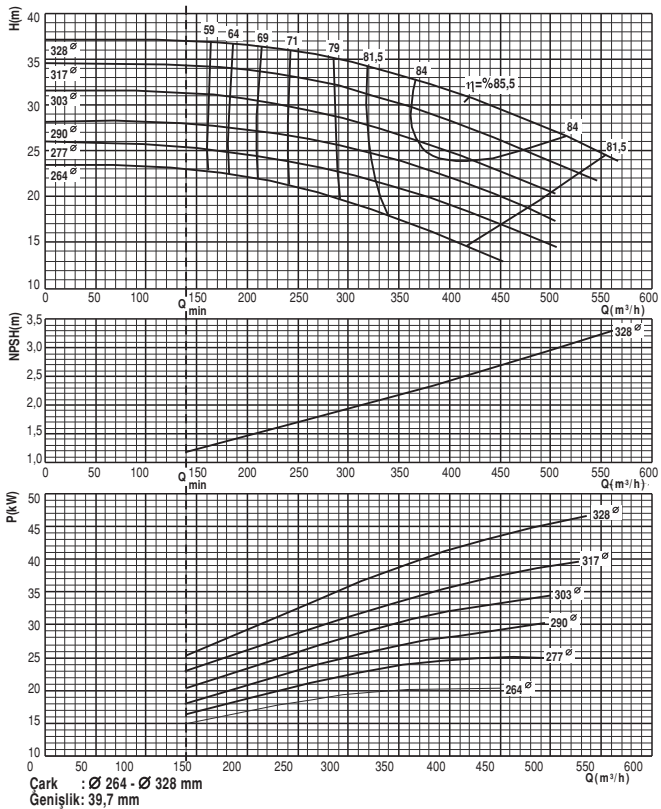

Mega 150-400

1450 d/dak

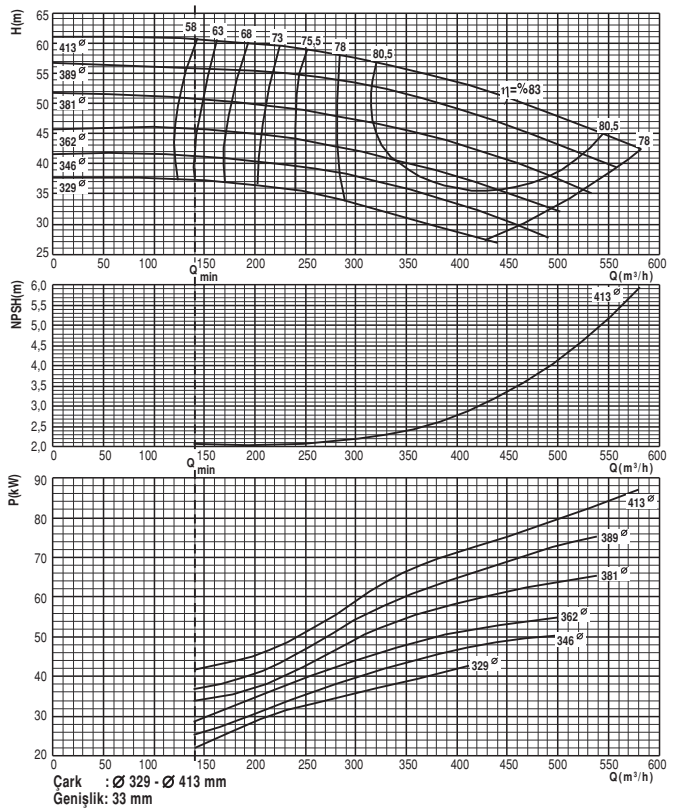

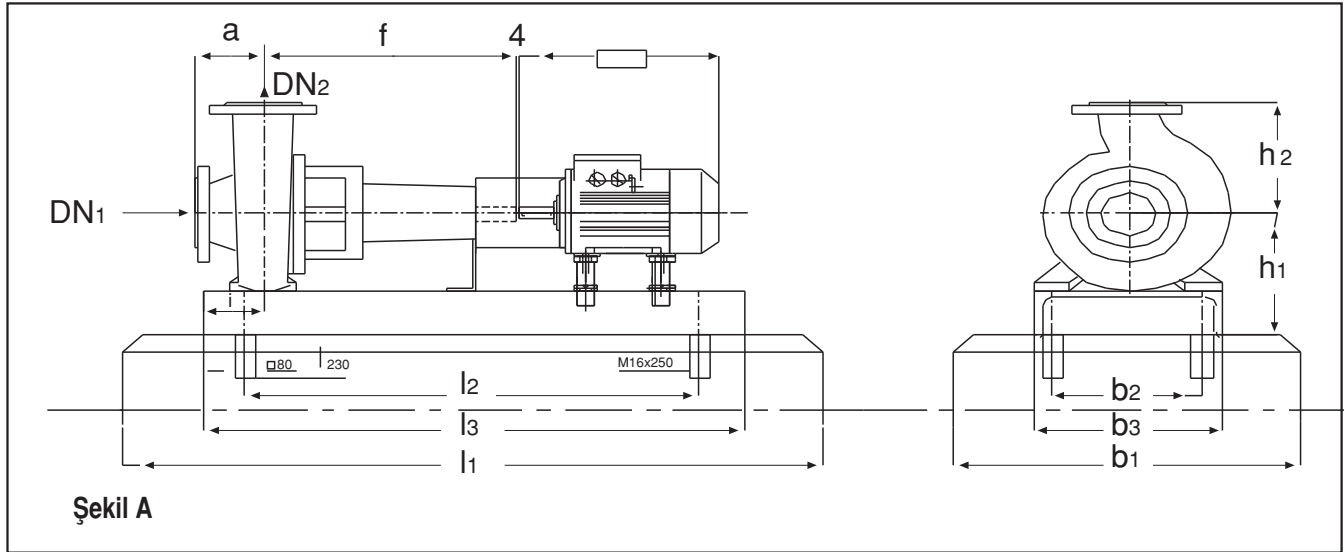
BETA 32-125 - 40-125

BETA	2900 d/dak kW	1450	Motor Gövde Ölçüsü	Şekil	DN1	DN2	a	b1	b2	b3	f	h1	h2	l					
															l1	l2	l3	FIG 0 KG	FIG 3 KG
32-125		0.55	80	A	50	32	80	450	240	300	360	212	140	80	860	650	710	25	58
	1.1		80	A	50	32	80	450	240	300	360	212	140	80	860	650	710	25	58
	1.5		90 S	A	50	32	80	450	240	300	360	212	140	80	950	740	800	25	62
	2.2		90 L	A	50	32	80	450	240	300	360	212	140	80	950	740	800	25	62
	3		100 L	A	50	32	80	450	240	300	360	212	140	80	950	740	800	25	62
32-160		0.55	80	A	50	32	80	450	240	300	360	232	160	112	860	650	710	28	61
	1.5		90 S	A	50	32	80	450	240	300	360	232	160	112	950	740	800	28	63
	2.2		90 L	A	50	32	80	450	240	300	360	232	160	112	950	740	800	28	65
	3		100 L	A	50	32	80	450	240	300	360	232	160	112	1050	840	900	28	67
	4		112 M	A	50	32	80	450	240	300	360	232	160	112	1050	840	900	28	67
32-200		0.55	80	A	50	32	80	450	240	300	360	260	180	112	860	650	710	35	68
		0.75	80	A	50	32	80	450	240	300	360	260	180	112	860	650	710	35	68
		1.1	90 S	A	50	32	80	450	240	300	360	260	180	112	950	740	800	35	72
	3		100 L	A	50	32	80	450	240	300	360	260	180	112	1050	840	900	35	73
	4		112 M	A	50	32	80	450	240	300	360	260	180	112	1050	840	900	35	74
	5.5		132 S	A	50	32	80	450	240	300	360	260	180	112	1050	840	900	35	92
	7.5		132 S	A	50	32	80	450	240	300	360	260	180	112	1050	840	900	35	92
	11		160 M	A	50	32	80	510	300	360	360	270	180	112	1270	1060	1120	35	105
32-250		1.1	90 S	A	50	32	100	510	300	360	360	290	225	120	950	740	800	46	96
		1.5	90 L	A	50	32	100	510	300	360	360	290	225	120	950	740	800	46	96
		2.2	100 L	A	50	32	100	510	300	360	360	290	225	120	1050	840	900	46	99
		3	100 L	A	50	32	100	510	300	360	360	290	225	120	1050	840	900	46	99
	7.5		132 S	A	50	32	100	510	300	360	360	290	225	120	1150	940	1000	46	103
	11		160 M	A	50	32	100	510	300	360	360	290	225	120	1270	1060	1120	46	116
	15		160 M	A	50	32	100	510	300	360	360	290	225	120	1270	1060	1120	46	116
40-125		0.55	80	A	65	40	80	450	240	300	360	212	140	112	860	650	710	26	59
		0.75	80	A	65	40	80	450	240	300	360	212	140	112	860	650	710	26	59
		1.1	90 S	A	65	40	80	450	240	300	360	212	140	112	950	740	800	26	63
	1.5		90 S	A	65	40	80	450	240	300	360	212	140	112	950	740	800	26	63
	2.2		90 L	A	65	40	80	450	240	300	360	212	140	112	950	740	800	26	63
	3		100 L	A	65	40	80	450	240	300	360	212	140	112	950	740	800	26	64
	4		112 M	A	65	40	80	450	240	300	360	212	140	112	1050	840	900	26	65

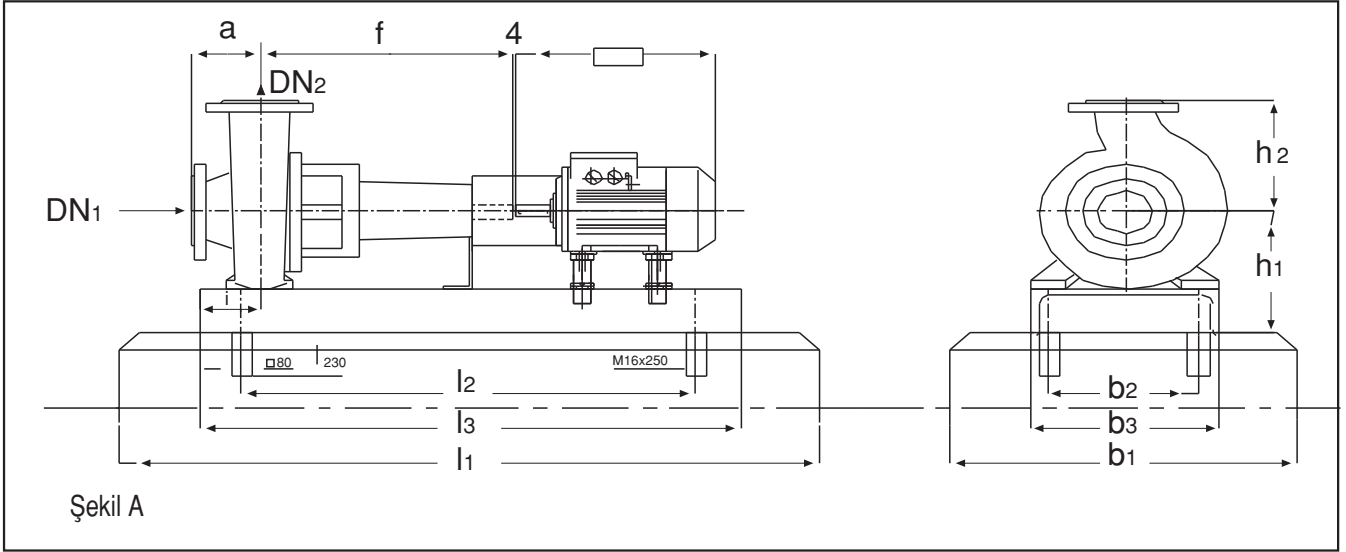
BETA 40-160 - 50-125

BETA	2900 d/dak	1450 kW	Motor Gövde Ölçüsü	Şekil	DN1	DN2	a	b1	b2	b3	f	h1	h2	l				FIG 0 KG	FIG 3 KG
															l1	l2	l3		
40-160		0.55	80	A	65	40	80	450	240	300	360	232	160	112	860	650	710	30	63
		0.75	80	A	65	40	80	450	240	300	360	232	160	112	860	650	710	30	63
		1.1	90 S	A	65	40	80	450	240	300	360	232	160	112	950	740	800	30	67
		3	100 L	A	65	40	80	450	240	300	360	232	160	112	1000	840	900	30	67
		4	112 M	A	65	40	80	450	240	300	360	232	160	112	1000	840	900	30	69
		5.5	132 S	A	65	40	80	510	300	360	360	242	160	112	1050	840	900	30	87
		7.5	132 S	A	65	40	80	510	300	360	360	242	160	112	1050	840	900	30	87
40-200		0.75	80	A	65	40	100	450	240	300	360	260	180	112	860	650	710	38	71
		1.1	90 S	A	65	40	100	450	240	300	360	260	180	112	950	740	800	38	75
		1.5	90 L	A	65	40	100	450	240	300	360	260	180	112	950	740	800	38	75
		5.5	132 S	A	65	40	100	510	300	360	360	270	180	112	1050	840	900	38	95
		7.5	132 S	A	65	40	100	510	300	360	360	270	180	112	1050	840	900	38	95
		11	160 M	A	65	40	100	510	300	360	360	270	180	112	1270	1060	1120	38	108
40-250		1.1	90 S	A	65	40	100	510	300	360	360	290	225	120	950	740	800	47	97
		1.5	90 L	A	65	40	100	510	300	360	360	290	225	120	950	740	800	47	97
		2.2	100 L	A	65	40	100	510	300	360	360	290	225	120	1050	840	900	47	100
		3	100 L	A	65	40	100	510	300	360	360	290	225	120	1050	840	900	47	100
		11	160 M	A	65	40	100	510	300	360	360	290	225	120	1270	1060	1120	47	117
		15	160 M	A	65	40	100	510	300	360	360	290	225	120	1270	1060	1120	47	117
		18.5	160 L	A	65	40	100	510	300	360	360	290	225	120	1270	1060	1120	47	117
		22	180 M	A	65	40	100	550	320	400	360	295	225	120	1350	1190	1200	47	140
40/315		2.2	100 L	A	65	40	125	510	300	360	500	310	250	120	1150	940	1000	86	175
		3	100 L	A	65	40	125	510	300	360	500	310	250	120	1150	940	1000	86	177
		4	112 M	A	65	40	125	510	300	360	500	310	250	120	1150	940	1000	86	195
		5.5	132 S	A	65	40	125	510	300	360	500	310	250	120	1270	1060	1120	86	203
50-125		0.55	80	A	65	50	100	450	240	300	360	232	160	112	860	650	710	29	62
		0.75	80	A	65	50	100	450	240	300	360	232	160	112	860	650	710	29	62
		1.1	90 S	A	65	50	100	450	240	300	360	232	160	112	950	740	800	29	66
		3	100 L	A	65	50	100	450	240	300	360	232	160	112	1050	840	900	29	68
		4	112 M	A	65	50	100	450	240	300	360	232	160	112	1050	840	900	29	68
		5.5	132 S	A	65	50	100	450	240	300	360	232	160	112	1050	840	900	29	86
		7.5	132 S	A	65	50	100	450	240	300	360	232	160	112	1050	840	900	29	86

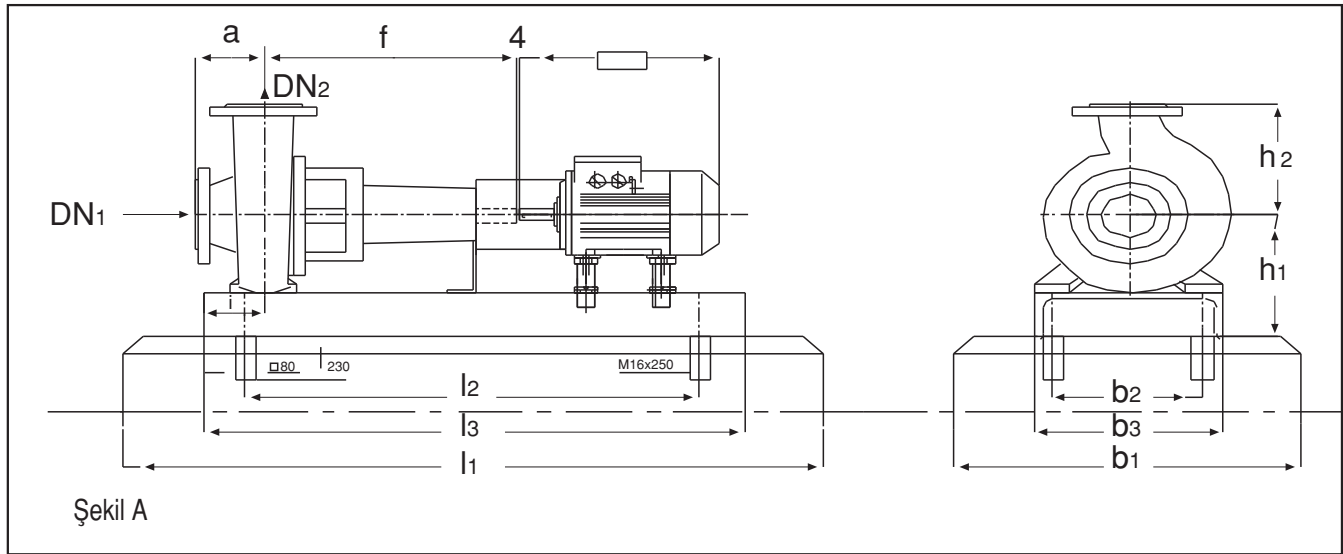
BETA 50-160 - 65-125

BETA	2900 d/dak kW	1450 Motor Gövde Ölçüsü	Şekil	DN1	DN2	a	b1	b2	b3	f	h1	h2	l	FIG 0			FIG 3	
														l1	l2	l3	KG	KG
50-160	0.75	80	A	65	50	100	450	240	300	360	260	180	112	860	650	710	31	64
	1.1	90 S	A	65	50	100	450	240	300	360	260	180	112	950	740	800	31	68
	1.5	90 L	A	65	50	100	450	240	300	360	260	180	112	950	740	800	31	68
	3	100 L	A	65	50	100	450	240	300	360	260	180	112	950	740	800	31	76
	4	112 M	A	65	50	100	450	240	300	360	260	180	112	1000	790	850	31	80
	5.5	132 S	A	65	50	100	510	300	360	360	270	180	112	1050	840	900	31	88
	7.5	132 S	A	65	50	100	510	300	360	360	270	180	112	1050	840	900	31	88
	11	160 M	A	65	50	100	510	300	360	360	270	180	112	1270	1060	1120	31	101
50-200	1.5	90 L	A	65	50	100	450	240	300	360	260	200	112	950	740	800	40	77
	2.2	100 L	A	65	50	100	450	240	300	360	260	200	112	1050	840	900	40	79
	3	100 L	A	65	50	100	450	240	300	360	260	200	112	1050	840	900	40	79
	5.5	132 S	A	65	50	100	450	240	300	360	260	200	112	1050	840	900	40	105
	7.5	132 S	A	65	50	100	450	240	300	360	260	200	112	1050	840	900	40	105
	11	160 M	A	65	50	100	510	300	360	360	270	200	112	1270	1060	1120	40	110
	15	160 M	A	65	50	100	510	300	360	360	270	200	112	1270	1060	1120	40	110
	18.5	160 L	A	65	50	100	510	300	360	360	270	200	112	1270	1060	1120	40	110
50-250	2.2	100 L	A	65	50	100	510	300	360	360	290	225	120	1050	840	900	49	102
	3	100 L	A	65	50	100	510	300	360	360	290	225	120	1050	840	900	49	102
	4	112 M	A	65	50	100	510	300	360	360	290	225	120	1050	840	900	49	102
	15	160 M	A	65	50	100	510	300	360	360	290	225	120	1270	1060	1120	49	119
	18.5	160 L	A	65	50	100	510	300	360	360	290	225	120	1270	1060	1120	49	119
	22	180 M	A	65	50	100	550	320	400	360	295	225	120	1400	1190	1250	49	142
	30	200 L	A	65	50	100	550	320	400	360	315	225	120	1400	1190	1250	49	142
50-315	3	100 L	A	80	50	125	510	300	360	500	335	280	120	1150	940	1000	89	180
	4	112 M	A	80	50	125	510	300	360	500	335	280	120	1150	940	1000	89	198
	5.5	132 S	A	80	50	125	510	300	360	500	335	280	120	1270	1060	1120	89	206
	7.5	132 M	A	80	50	125	510	300	360	500	335	280	120	1270	1060	1120	89	230
65-125	0.55	80	A	80	65	100	450	240	300	360	260	180	120	950	740	800	34	71
	0.75	80	A	80	65	100	450	240	300	360	260	180	120	950	740	800	34	71
	1.1	90 S	A	80	65	100	450	240	300	360	260	180	120	950	740	800	34	71
	4	112 M	A	80	65	100	450	240	300	360	260	180	120	1050	840	900	34	73
	5.5	132 S	A	80	65	100	510	300	360	360	270	180	120	1050	840	900	34	91
	7.5	132 S	A	80	65	100	510	300	360	360	270	180	120	1050	840	900	34	91
11	160 M	A	80	65	100	510	300	360	360	270	180	120	1270	1060	1120	34	104	

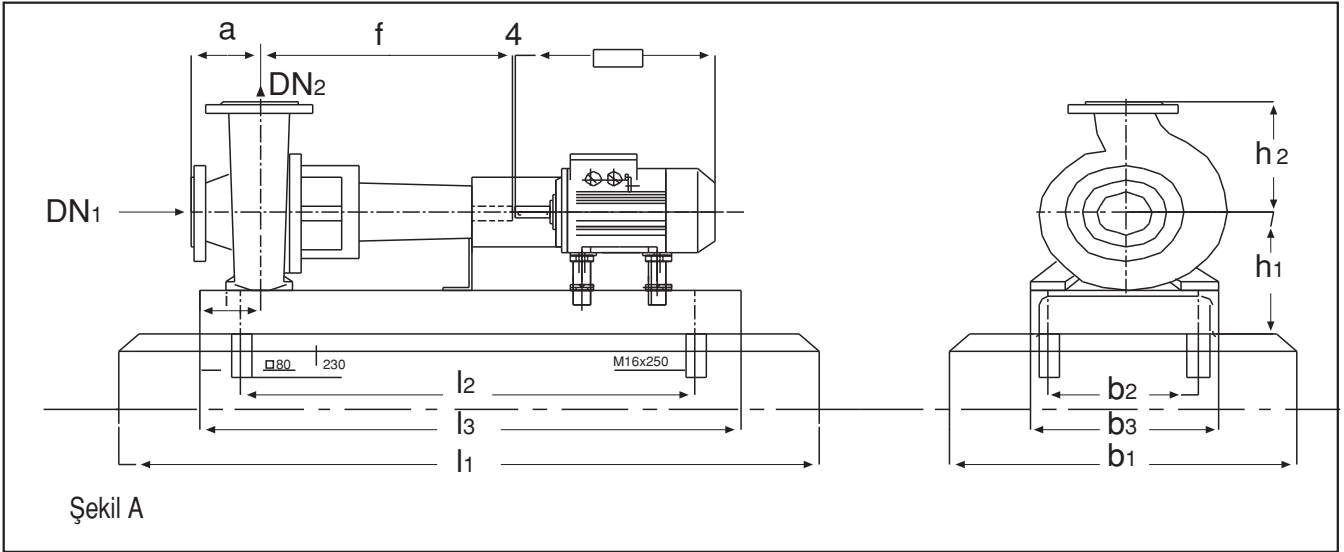
BETA 65-160 - 65-200

BETA	2900 d/dak kW	1450 Motor Gövde Ölçüsü	Şekil	DN1	DN2	a	b1	b2	b3	f	h1	h2	l	FIG 0			FIG 3	
														l1	l2	l3	KG	KG
65-160	1.1	90	A	80	65	100	450	240	300	360	260	200	120	950	740	800	40	77
	1.5	90 L	A	80	65	100	450	240	300	360	260	200	120	950	740	800	40	77
	2.2	100 L	A	80	65	100	450	240	300	360	260	200	120	1050	840	900	40	79
	7.5	132 S	A	80	65	100	510	300	360	360	270	200	120	1050	840	900	40	97
	11	160 M	A	80	65	100	510	300	360	360	270	200	120	1270	1060	1120	40	110
	15	160 M	A	80	65	100	510	300	360	360	270	200	120	1270	1060	1120	40	110
65-200	18.5	160 M	A	80	65	100	510	300	360	360	270	200	120	1270	1060	1120	40	119
	2.2	100 L	A	80	65	100	510	300	360	360	290	225	120	1050	840	900	44	97
	3	100 L	A	80	65	100	510	300	360	360	290	225	120	1050	840	900	44	97
	4	112 M	A	80	65	100	510	300	360	360	290	225	120	1050	840	900	44	104
	15	160 M	A	80	65	100	510	300	360	360	290	225	120	1270	1060	1120	44	114
	18.5	160 L	A	80	65	100	510	300	360	360	290	225	120	1270	1060	1120	44	114
	22	180 M	A	80	65	100	550	320	400	360	295	225	120	1270	1060	1120	44	137
30	200 L	A	80	65	100	550	320	400	360	315	225	120	1400	1190	1250	44	186	

BETA 65-250 - 80-160

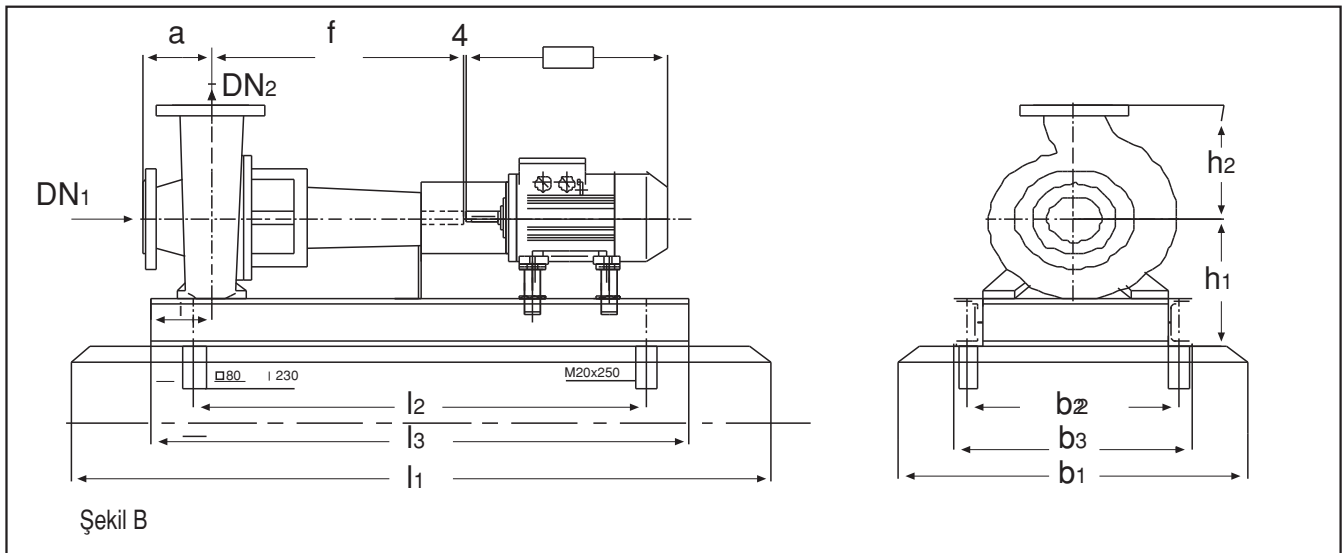
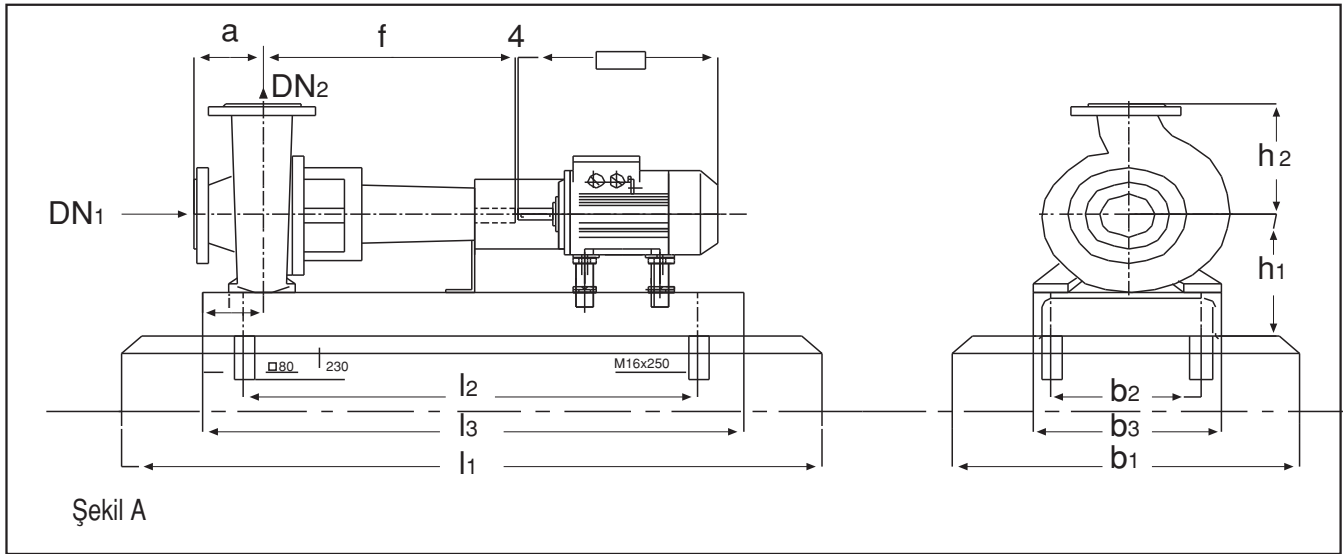

BETA	2900 d/dak kW	1450	Motor Gövde Ölçüsü	Şekil	DN1	DN2	a	b1	b2	b3	f	h1	h2	l				FIG 0 KG	FIG 3 KG
															l1	l2	l3		
65-250		3	100 L	A	100	65	125	550	320	400	500	315	250	135	1150	940	1000	77	185
		4	112 M	A	100	65	125	550	320	400	500	315	250	135	1150	940	1000	77	205
		5.5	132 S	A	100	65	125	550	320	400	500	315	250	135	1270	1060	1120	77	210
		22	180 M	A	100	65	125	550	320	400	500	315	250	135	1350	1140	1200	77	180
		30	200 L	A	100	65	125	550	320	400	500	315	250	135	1450	1240	1300	77	415
		37	200 L	A	100	65	125	550	320	400	500	315	250	135	1450	1240	1300	77	440
Fig B	45	*	225 M	B	100	65	125	700	500	550	500	360	250	135	1550	1100	1400	77	472
65-315		5.5	132 S	A	100	65	125	550	320	400	530	340	280	135	1270	1060	1120	93	224
		7.5	132 M	A	100	65	125	550	320	400	530	340	280	135	1270	1060	1120	93	240
		11	160 M	A	100	65	125	550	320	400	530	340	280	135	1400	1190	1250	93	268
80-160		2.2	100 L	A	100	80	125	510	300	360	360	290	225	120	1050	840	900	47	100
		3	100 L	A	100	80	125	510	300	360	360	290	225	120	1050	840	900	47	100
		15	160 M	A	100	80	125	510	300	360	360	290	225	120	1270	1060	1120	47	117
		18.5	160 L	A	100	80	125	510	300	360	360	290	225	120	1270	1060	1120	47	117
		22	180 M	A	100	80	125	550	320	400	360	295	225	120	1270	1060	1120	47	140
		30	200 L	A	100	80	125	550	320	400	360	315	225	120	1400	1190	1250	47	189

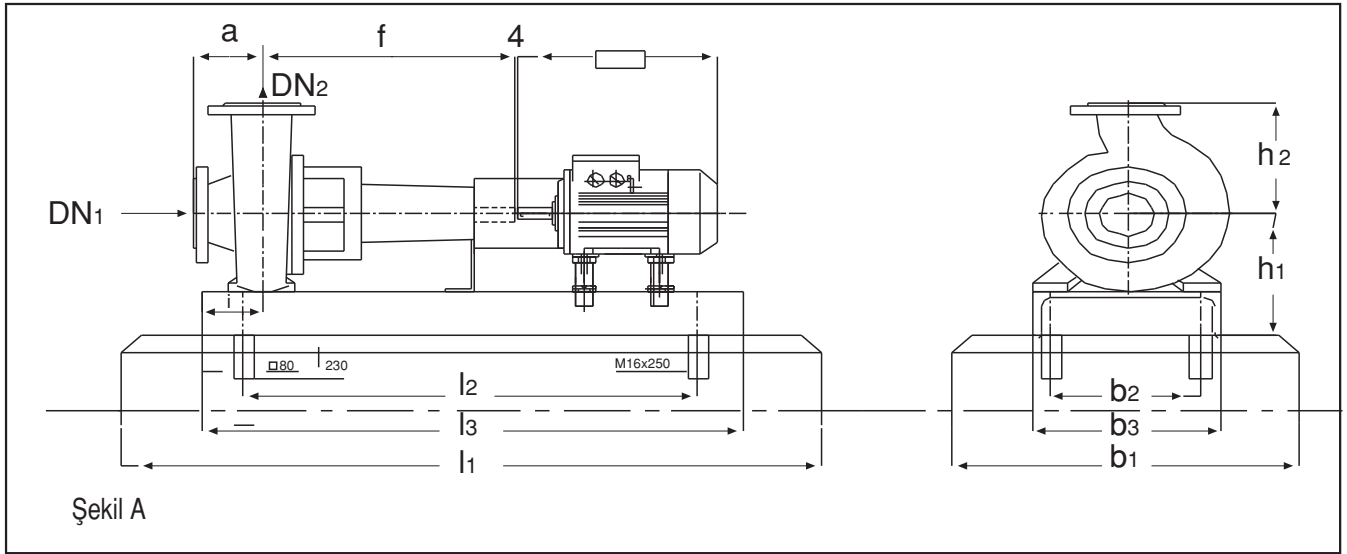
BETA 80-315

BETA	2900 d/dak kW	1450	Motor Gövde Ölçüsü	Şekil	DN1	DN2	a	b1	b2	b3	f	h1	h2	l	l1	l2	l3	FIG 0	FIG 3
																		KG	KG
80-315	7.5		132 M	A	100	80	125	550	320	400	530	365	315	135	1270	1060	1120	104	250
	11		160 M	A	100	80	125	550	320	400	530	365	315	135	1400	1190	1250	104	296
	15		160 L	A	100	80	125	550	320	400	530	365	315	135	1400	1190	1250	104	314
	18.5		180 M	A	100	80	125	550	320	400	530	365	315	135	1550	1340	1400	104	375
	22		180 L	A	100	80	125	550	320	400	530	365	315	135	1550	1340	1400	104	395

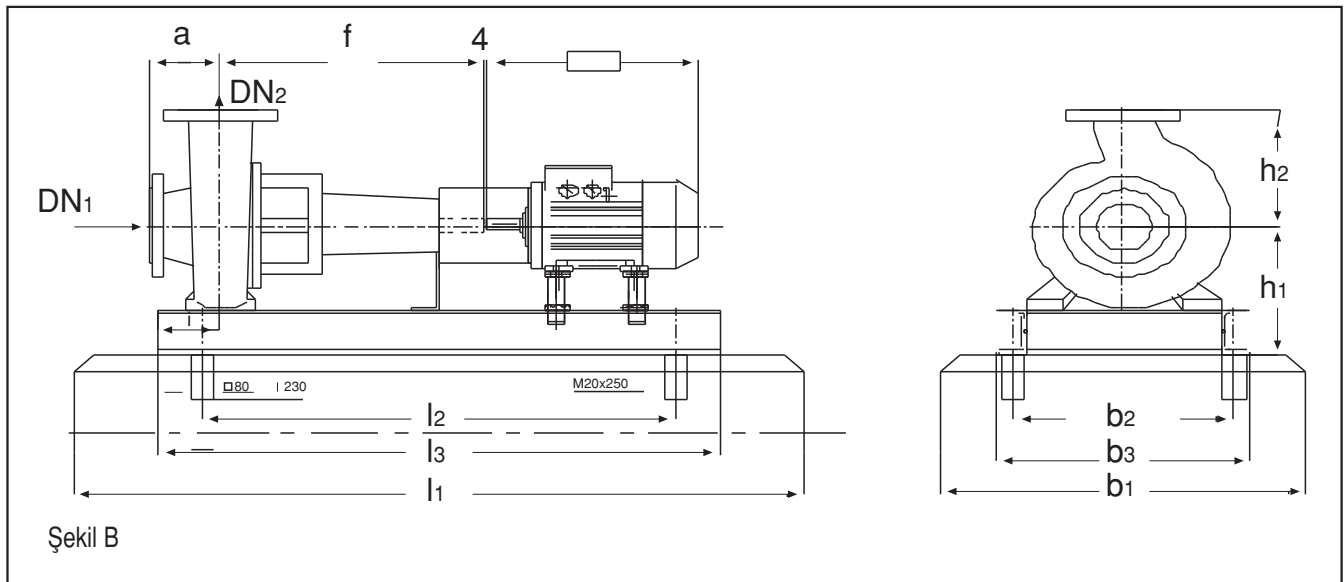
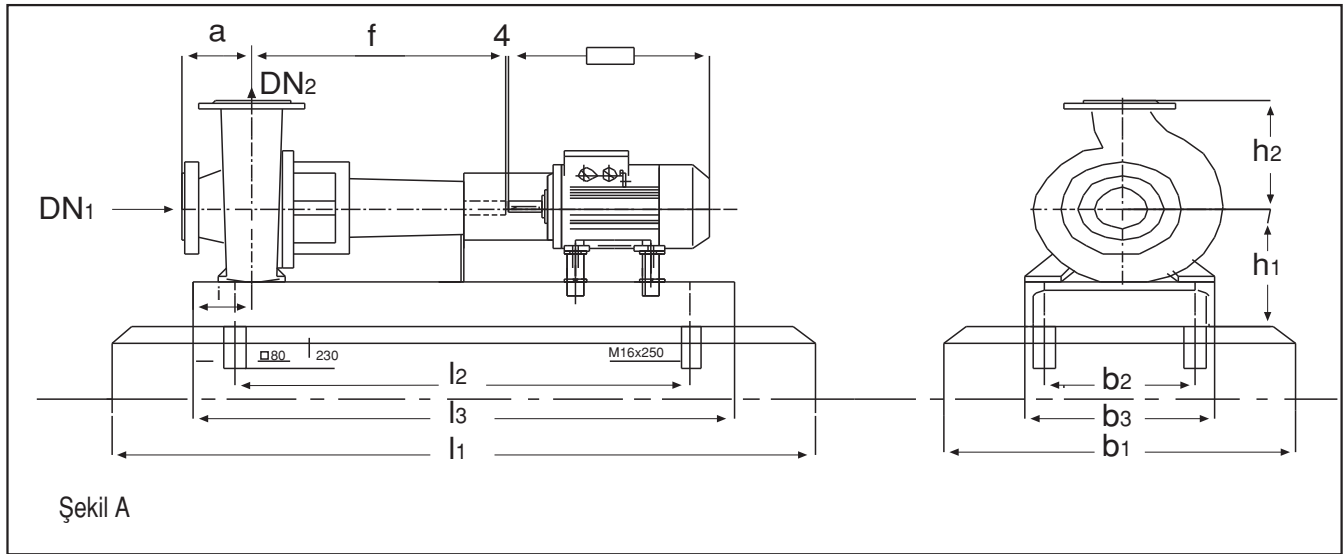
MEGA 80-200 - 80-250

MEGA	2900 d/dak	1450 kW	Motor Gövde Ölçüsü	Şekil	DN1	DN2	a	b1	b2	b3	f	h1	h2	l	l1	l2	l3	FIG 0 KG	FIG 3 KG
80-200		2.2	100 L	A	125	80	125	510	300	360	470	290	250	135	1050	840	900	80	108
		3	100 L	A	125	80	125	510	300	360	470	290	250	135	1050	840	900	80	170
		4	112 L	A	125	80	125	510	300	360	470	290	250	135	1050	840	900	80	188
		5.5	132 S	A	125	80	125	510	300	360	470	290	250	135	1150	940	1000	80	196
		18.5	160 L	A	125	80	125	510	300	360	470	290	250	135	1350	1140	1200	80	273
		22	180 M	A	125	80	125	550	320	400	470	295	250	135	1400	1190	1250	80	343
		30	200 L	A	125	80	125	550	320	400	470	310	250	135	1400	1190	1250	80	415
		37	200 L	A	125	80	125	550	320	400	470	310	250	135	1400	1190	1250	80	440
	45	225 M	B	125	80	125	730	520	580	470	365	250	135	1550	1100	1400	80	469	
80-250		4	112 M	A	125	80	125	550	320	400	500	340	280	135	1150	940	1000	90	212
		5.5	132 S	A	125	80	125	550	320	400	500	340	280	135	1200	990	1050	90	220
		7.5	132 M	A	125	80	125	550	320	400	500	340	280	135	1250	1040	1100	90	236
		11	160 M	A	125	80	125	550	320	400	500	340	280	135	1350	1140	1200	90	281
		30	200 L	A	125	80	125	550	320	400	500	340	280	135	1450	1220	1300	90	427
		37	200 L	A	125	80	125	550	320	400	500	340	280	135	1450	1300	1300	90	452
		45	225 M	B	125	80	125	730	520	580	500	365	280	135	1550	900	1400	90	484
		55	250 M	B	125	80	125	790	580	640	500	390	280	135	1550	900	1400	90	578
	75	280 S	B	125	80	125	840	630	690	500	420	280	135	1750	1100	1600	90	712	

MEGA 80-400 - 100-200

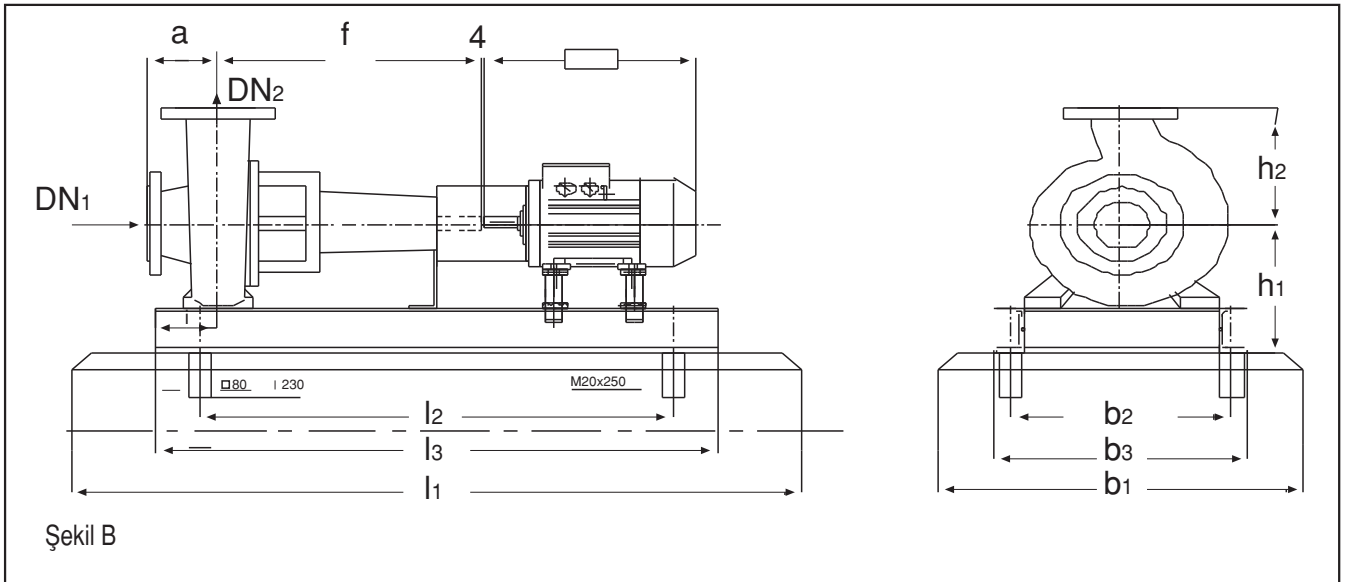
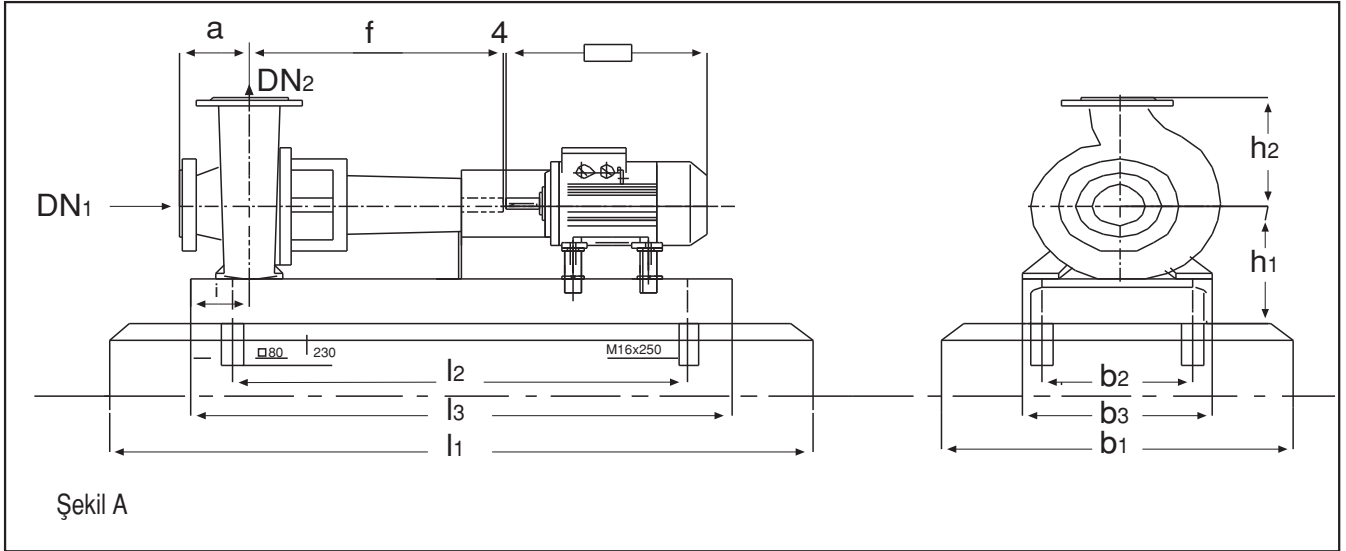

MEGA	2900 d/dak kW	1450 Motor Gövde Ölçüsü	Şekil	DN1	DN2	a	b1	b2	b3	f	h1	h2	l	l1	l2	l3	FIG 0 KG	FIG 3 KG
80-400	11	160 M	B	125	80	125	710	500	560	530	420	355	135	1400	950	1250	162	355
	15	160 L	B	125	80	125	710	500	560	530	420	355	135	1400	950	1250	162	390
	18.5	180 M	B	125	80	125	710	500	560	530	420	355	135	1400	950	1250	162	405
	22	180 L	B	125	80	125	710	500	560	530	420	355	135	1550	1100	1400	162	439
	30	200 L	B	125	80	125	710	500	560	530	420	355	135	1550	1100	1400	162	470
100-160	3	100 L	A	125	100	125	550	320	400	500	310	280	135	1150	940	1000	79	184
	4	112 M	A	125	100	125	550	320	400	500	310	280	135	1150	940	1000	79	202
	5.5	132 S	A	125	100	125	550	320	400	500	310	280	135	1200	990	1050	79	215
	22	180 M	A	125	100	125	550	320	400	500	310	280	135	1400	1190	1250	79	345
	30	200 L	A	125	100	125	550	320	400	500	310	280	135	1450	1240	1300	79	417
100-200	37	200 L	A	125	100	125	550	320	400	500	310	280	135	1450	1240	1300	79	442
	4	112 L	A	125	100	125	550	320	400	500	315	280	135	1150	940	1000	93	216
	5.5	132 S	A	125	100	125	550	320	400	500	315	280	135	1270	1060	1120	93	224
	7.5	132 M	A	125	100	125	550	320	400	500	315	280	135	1270	1060	1120	93	240
	30	200 L	A	125	100	125	550	320	400	500	315	280	135	1500	1290	1350	93	431
	37	200 L	A	125	100	125	550	320	400	500	315	280	135	1500	1290	1350	93	456
	45	225 M	B	125	100	125	730	520	580	500	365	280	135	1550	1100	1400	93	488
	55	250 M	B	125	100	125	790	580	640	500	390	280	135	1550	1100	1400	93	580
75	280 S	B	125	100	125	840	630	690	500	420	280	135	1750	1300	1600	93	723	

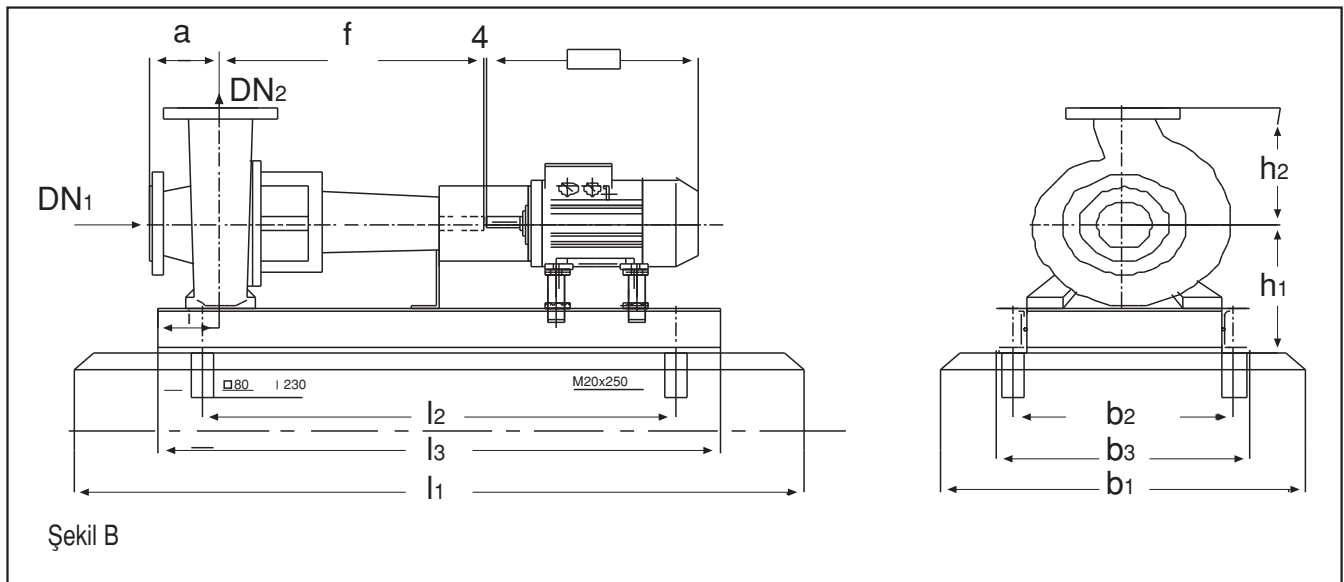
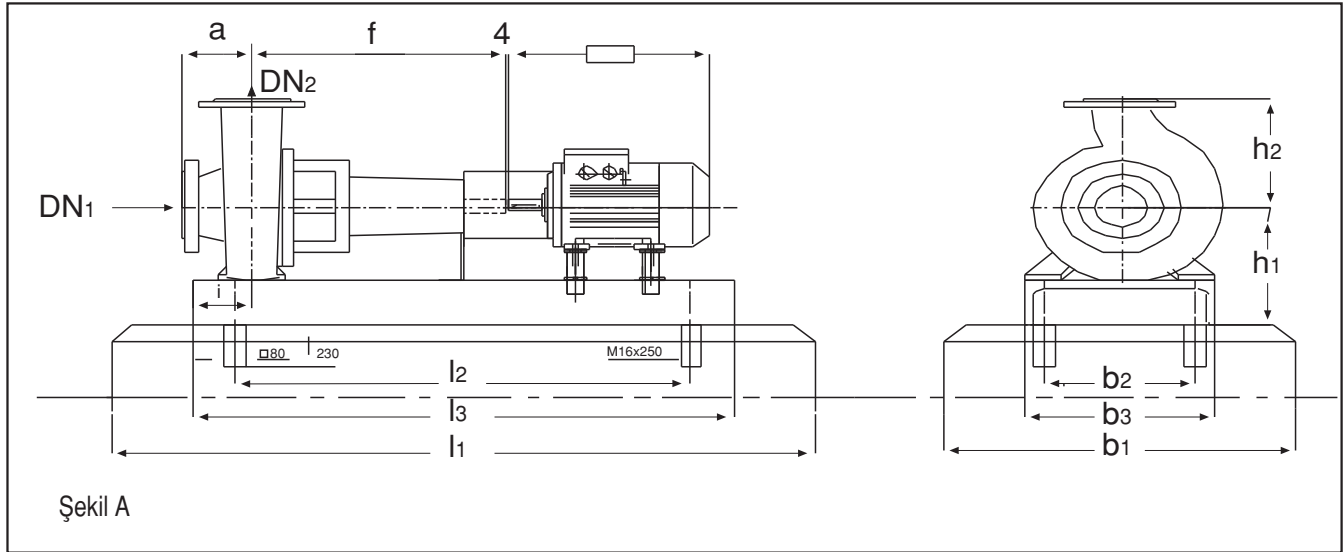
MEGA 100-250 - 125-200

MEGA	2900 d/dak	1450 kW	Motor Gövde Ölçüsü	Şekil	DN1	DN2	a	b1	b2	b3	f	h1	h2	l	l1	l2	l3	FIG 0 KG	FIG 3 KG
100-250		7.5	132 M	A	125	100	140	550	320	400	530	340	280	135	1270	1060	1120	103	250
		11	160 M	A	125	100	140	550	320	400	530	340	280	135	1400	1190	1250	103	280
		15	160 L	A	125	100	140	550	320	400	530	340	280	135	1400	1190	1250	103	315
		55	250 M	B	125	100	140	800	590	650	530	390	280	135	1750	1300	1600	103	590
		75	280 S	B	125	100	140	800	590	650	530	420	280	135	1750	1300	1600	103	732
100-315		90	280 M	B	125	100	140	800	590	650	530	420	280	135	1750	1300	1600	103	755
		15	160 L	A	125	100	140	550	320	400	530	340	280	135	1400	1190	1250	114	325
		18.5	180 M	A	125	100	140	550	320	400	530	340	280	135	1550	1340	1400	114	390
		22	180 L	A	125	100	140	550	320	400	530	340	280	135	1550	1340	1400	114	405
100-400		30	200 L	A	125	100	140	550	320	400	530	340	280	135	1550	1340	1400	114	419
		22	180 L	B	125	100	140	770	560	620	530	420	355	120	1550	1100	1400	180	476
		30	200 L	B	125	100	140	770	560	620	530	420	355	120	1550	1100	1400	180	503
125-200		37	225 S	B	125	100	140	770	560	620	530	420	355	120	1550	1100	1400	180	573
		7.5	132 M	A	150	125	140	550	320	400	470	365	315	135	1150	940	1000	113	264
		11	160 M	A	150	125	140	550	320	400	470	365	315	135	1400	1190	1250	113	306
		15	160 L	A	150	125	140	550	320	400	470	365	315	135	1400	1190	1250	113	323
		55	250 M	B	150	125	140	800	600	650	470	390	315	135	1750	1300	1600	113	666
	75	280 S	B	150	125	140	870	670	720	470	420	315	135	1750	1300	1600	113	808	
	90	280 M	B	150	125	140	870	670	720	470	420	315	135	1750	1300	1600	113	860	

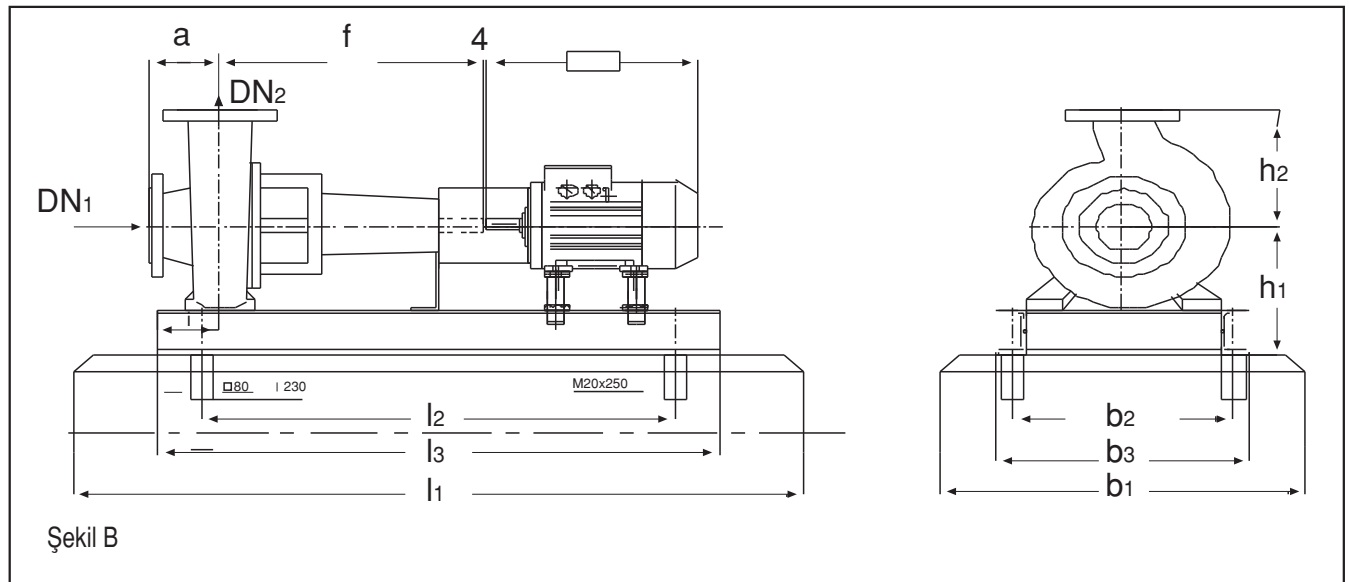
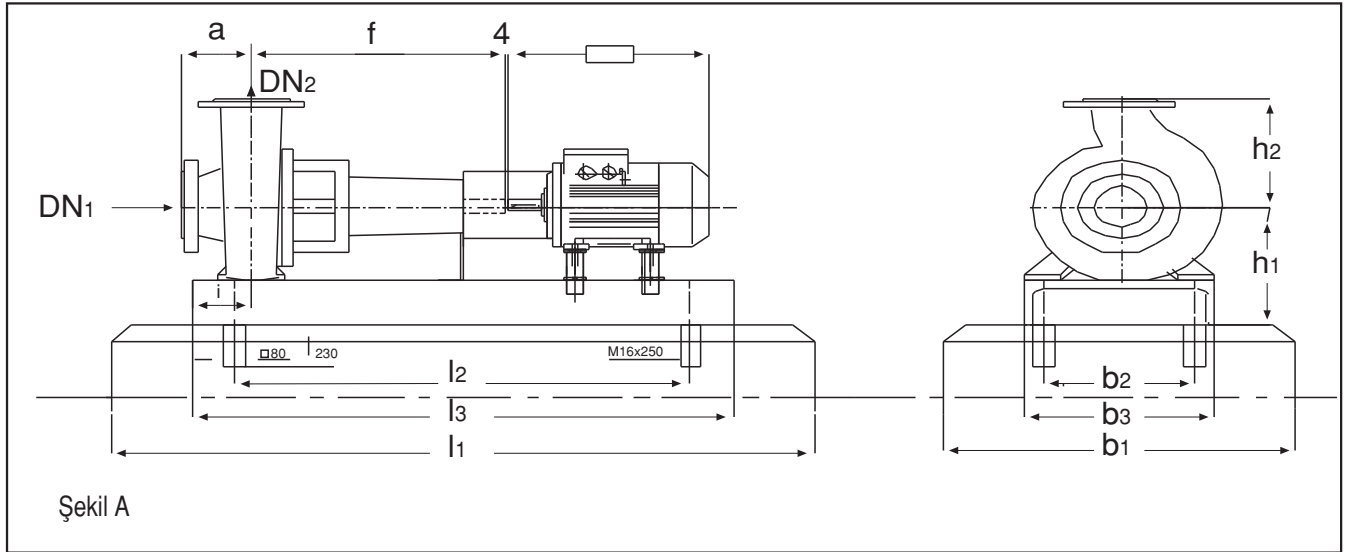
MEGA 125-250 - 150-200

MEGA	2900 1450 d/dak kW	Motor Gövde Ölçüsü	Şekil	DN1	DN2	a	b1	b2	b3	f	h1	h2	l				FIG 0 KG	FIG 3 KG
														l1	l2	l3		
125-250	11	160 M	A	150	125	140	550	320	400	530	365	355	135	1400	1190	1250	127	320
	15	160 L	A	150	125	140	550	320	400	530	365	355	135	1400	1190	1250	127	340
	18.5	180 M	A	150	125	140	550	320	400	530	365	355	135	1550	1340	1400	127	400
125-315	18.5	180 M	B	150	125	140	800	590	650	530	420	355	112	1550	1100	1400	165	427
	22	180 L	B	150	125	140	800	590	650	530	420	355	112	1550	1100	1400	165	461
	30	200 L	B	150	125	140	800	590	650	530	420	355	112	1550	1100	1400	165	490
	37	225 S	B	150	125	140	800	590	650	530	420	355	112	1550	1100	1400	165	560
125-400	30	200 L	B	150	125	140	800	590	650	530	455	400	112	1550	1100	1400	200	526
	37	225 S	B	150	125	140	800	590	650	530	455	400	112	1550	1100	1400	200	592
	45	225 M	B	150	125	140	800	590	650	530	455	400	112	1550	1100	1400	200	625
	55	250 M	B	150	125	140	800	590	650	530	455	400	112	1750	1300	1600	200	700
	75	280 S	B	150	125	140	800	590	650	530	455	400	112	1750	1300	1600	200	884
150-200	11	160 M	B	200	150	160	840	630	690	530	420	400	135	1350	900	1200	173	394
	15	160 L	B	200	150	160	840	630	690	530	420	400	135	1350	900	1200	173	428

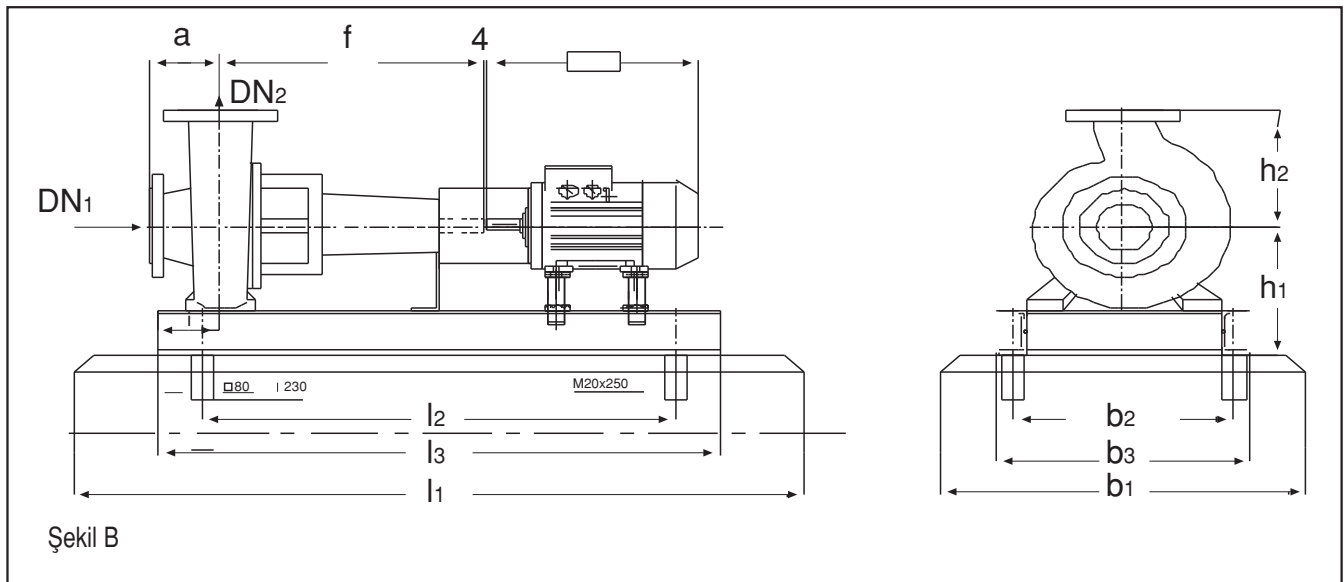
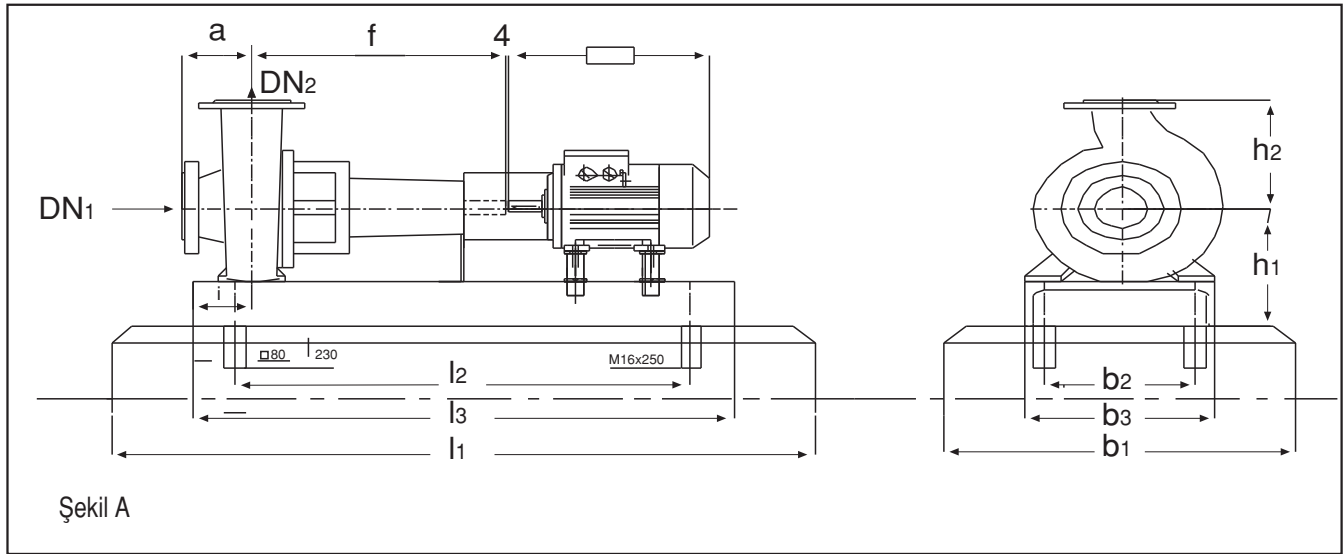
MEGA 150-250 - 150-400

MEGA	2900 d/dak	1450 kW	Motor Gövde Ölçüsü	Şekil	DN1	DN2	a	b1	b2	b3	f	h1	h2	l	l1	l2	l3	FIG 0 KG	FIG 3 KG
150-250	15	160 L	B	200	150	160	790	580	640	530	420	375	135	1400	950	1250	162	408	
	18.5	180 M	B	200	150	160	790	580	640	530	420	375	135	1450	1000	1300	162	426	
	22	180 L	B	200	150	160	790	580	640	530	420	375	135	1450	1000	1300	162	460	
	30	200 L	B	200	150	160	790	580	640	530	420	375	135	1500	1050	1350	162	487	
150-315	22	180 L	B	200	150	160	840	630	690	670	455	400	112	1750	1300	1600	190	496	
	30	200 L	B	200	150	160	840	630	690	670	455	400	112	1750	1300	1600	190	525	
	37	225 S	B	200	150	160	840	630	690	670	455	400	112	1750	1300	1600	190	595	
	45	225 M	B	200	150	160	840	630	690	670	455	400	112	1750	1300	1600	190	625	
150-400	37	225 S	B	200	150	160	840	630	690	670	455	450	112	1750	1300	1600	225	630	
	45	225 M	B	200	150	160	840	630	690	670	455	450	112	1750	1300	1600	225	660	
	55	250 M	B	200	150	160	840	630	690	670	455	450	112	1750	1300	1600	225	735	
	75	280 S	B	200	150	160	840	630	690	670	455	450	112	1750	1300	1600	225	910	
	90	280 M	B	200	150	160	860	650	710	670	455	450	112	1850	1300	1700	225	975	



Ursan Pompa Armatür ve Endüstriyel Ürünler San. Tic. Ltd. Sti.

Güzeller Mah. Bagdat Cad. No: 601/A 41400 Gebze / KOCAELI
Tel: (0.262) 642 05 60 - 641 84 15 - 641 82 60 Fax: (0.262) 642 39 79
e-mail: kocaali@ksb.com.tr - ursan@ursanpompa.com
www.ursanpompa.com