

Kademeli Yüksek Basınç Pompası



Kullanım Alanları

- Her türlü su temini
- Yangın söndürme
- Yağmurlama - tarım
- Kazan besiy suyu
- Isıtma
- İçme suyu
- Sıcak su
- Soğutma suyu
- Havuz suyu
- Deniz suyu
- Az kirli sular
- Kondens suyu

İşletme Bilgileri

Debi	: 450 m ³ /h'e kadar.
Basma Yüksekliği	: 375 m'ye kadar.
Pompa Çıkış Ağız	: DN32 - DN150 arası
Çalışma Basıncı	: DN32-65 : maks.25bar*
	: DN80-150 : maks.40bar*
Çalışma Sıcaklığı	: -10°C ile +140°C arası

* Sıfır debideki basınç ile emiş tarafındaki basınçların toplamı bu değeri geçmemelidir.

Dizayn

Modüler dilimli yapı biçiminde yatay konumlu, tek veya çok kademeli, mil muhafaza burçları ile birlikte. Ayaklar giriş ve çıkış gövdesi ile tek parçadır.

Yataklar

Pompanın mili, pompanın yatak konsülüne yerleştirilen bilyalı yataklarla yataklanmış olup, eksenel kuvvetler, çarkların arkalarındaki denge kanatları ile, dengelenemeyenler ise silindirik merkezli yataklar ile dengelenmiştir.

Mil sızdırmazlığı

Salmastra kutuları bölgesinde; mil, değişebilir koruma burçları ile donatılmış olup, 90°C'ye kadar normal yumuşak salmastra, 90-140°C arası soğutmalı salmastra sistemi uygulanır. Mekanik salmastralı uygulamalarda 140°C'ye kadar soğutma suyuna ihtiyaç duyulmadan çalışabilir. Yumuşak salmastralı pompalarda emme tarafı salmastra kutusuna sıvı tahdit mayi halkası konular ve çıkış gövdesine bir irtibat borusu ile bağlanır.

Tanımlama

Tipi	WKL	150 / 3	G	1
Basma ağız DN				
Kademe sayısı				
Malzeme Kodu (G,M,B,S)				
Salmastra Tipi				
1- Yumuşak salmastra				
1- HW - Yumuşak salmastra - su soğutmalı				
16- Standart mekanik salmastra - max 140 °C su için				

Malzeme

Gövde baskı kapağı	: JL 1040 / JS 1025 / CC 480 K-GS
Fan	: JL 1040 / CC 480 K-GS
Difüzör	: JL 1040 / CC 480 K-GS
Mil	: St60
Yatak konsolu	: JL 1040
Salmastra / akışkan	: Yumuşak (1) / max.90°C
	: Yumuşak salmastra su soğutmalı(1-HW)/max140°C
	: Mekanik (16) / max140°C

Motor

Üç faz sincap kafesi asenkron motor.	
2,2 kW'a kadar	: 220-240 V / 380-420 V
3kW ve üzeri	: 380-420 V / 660-725 V
Dizayn	: IMB3
Koruma sınıfı	: IP 54 veya IP55
İzolasyon sınıfı	: F (opsiyonel olarak 3 termistörlü)
Çalışma modu	: Sürekli S1

Kaplin

Elastik kaplin ile elektrik motoruna bağlanır.
Kaplin koruyucu EN 294'e uygundur.

Kaide

Pompa ve motor için ortak çelik kaide.

n = 2900 d/dak

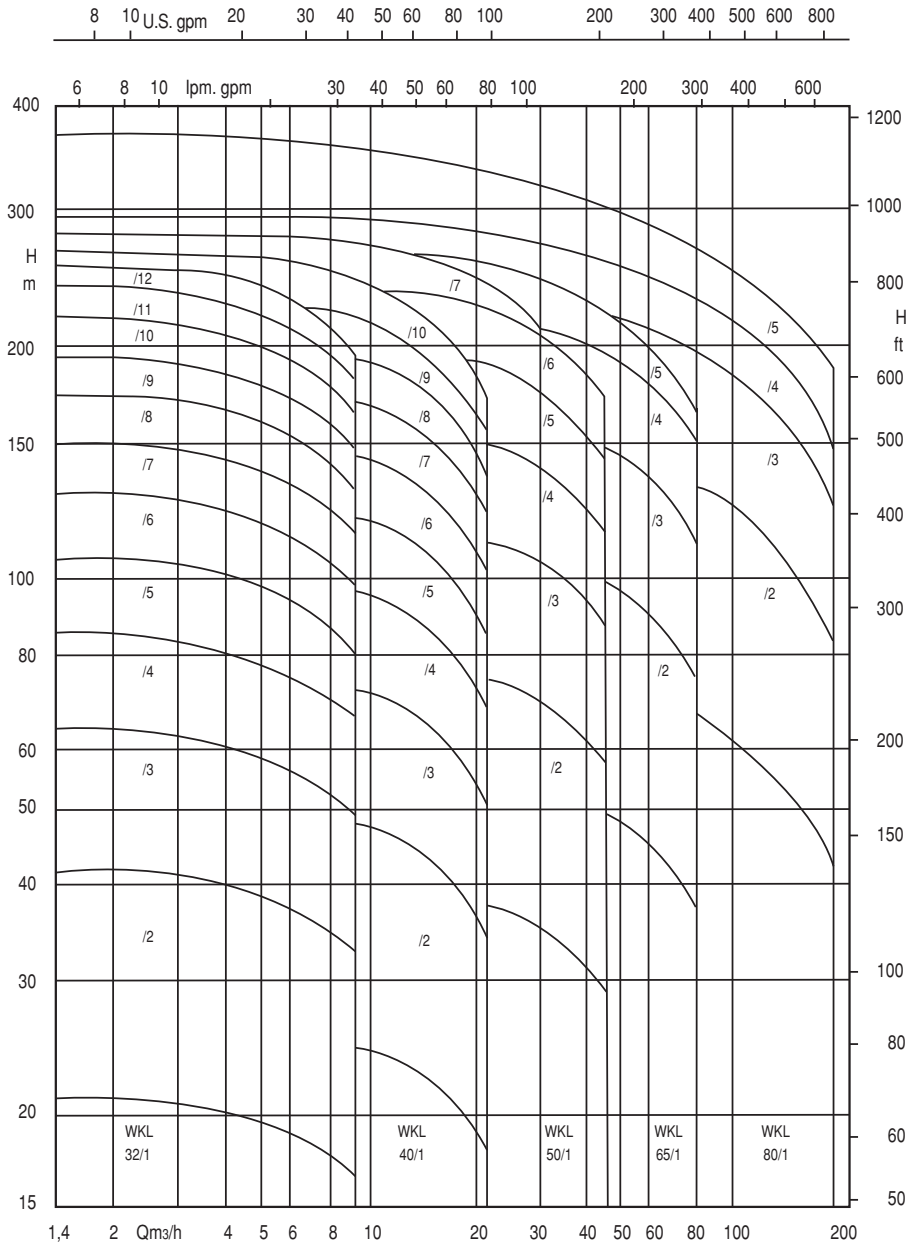

n = 1450 d/dak

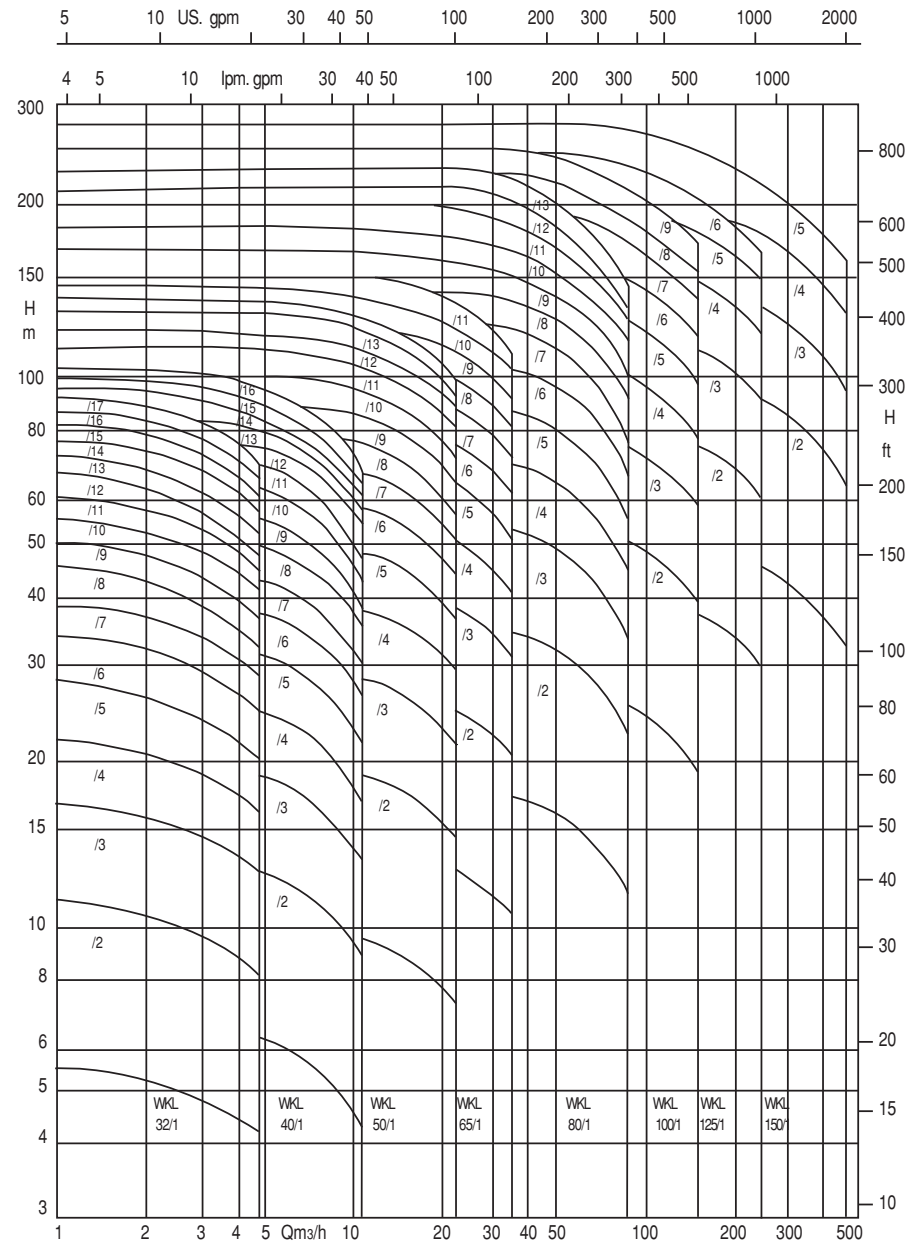

Malzeme Kombinasyonları

	WKL G	WKL M	WKL B	WKL S
Gövde	JL 1040 (Gri dökme demir)	JL 1040 (Gri dökme demir)	CC 480 K-GS (Bronz)	JS 1025 (Küresel grafitli dökme demir)
Baskı kapağı	JL 1040 (Gri dökme demir)	JL 1040 (Gri dökme demir)	CC 480 K-GS (Bronz)	JS 1025 (Küresel grafitli dökme demir)
Çark	JL 1040 (Gri dökme demir)	CC 480 K-GS (Bronz)	CC 480 K-GS (Bronz)	JL 1040 (Gri dökme demir)
Difüzör	JL 1040 (Gri dökme demir)	CC 480 K-GS (Bronz)	CC 480 K-GS (Bronz)	JL 1040 (Gri dökme demir)
Mil	ST 60 (Karbon çeliği)	ST 60 (Karbon çeliği)	ST 60 (Karbon çeliği)	ST 60 (Karbon çeliği)
Mil Burcu	JL 1040 (Gri dökme demir)	JL 1040 (Gri dökme demir)	JL 1040 (Gri dökme demir)	JL 1040 (Gri dökme demir)
Yatak Konsülü	JL 1040 (Gri dökme demir)	JL 1040 (Gri dökme demir)	JL 1040 (Gri dökme demir)	JL 1040 (Gri dökme demir)

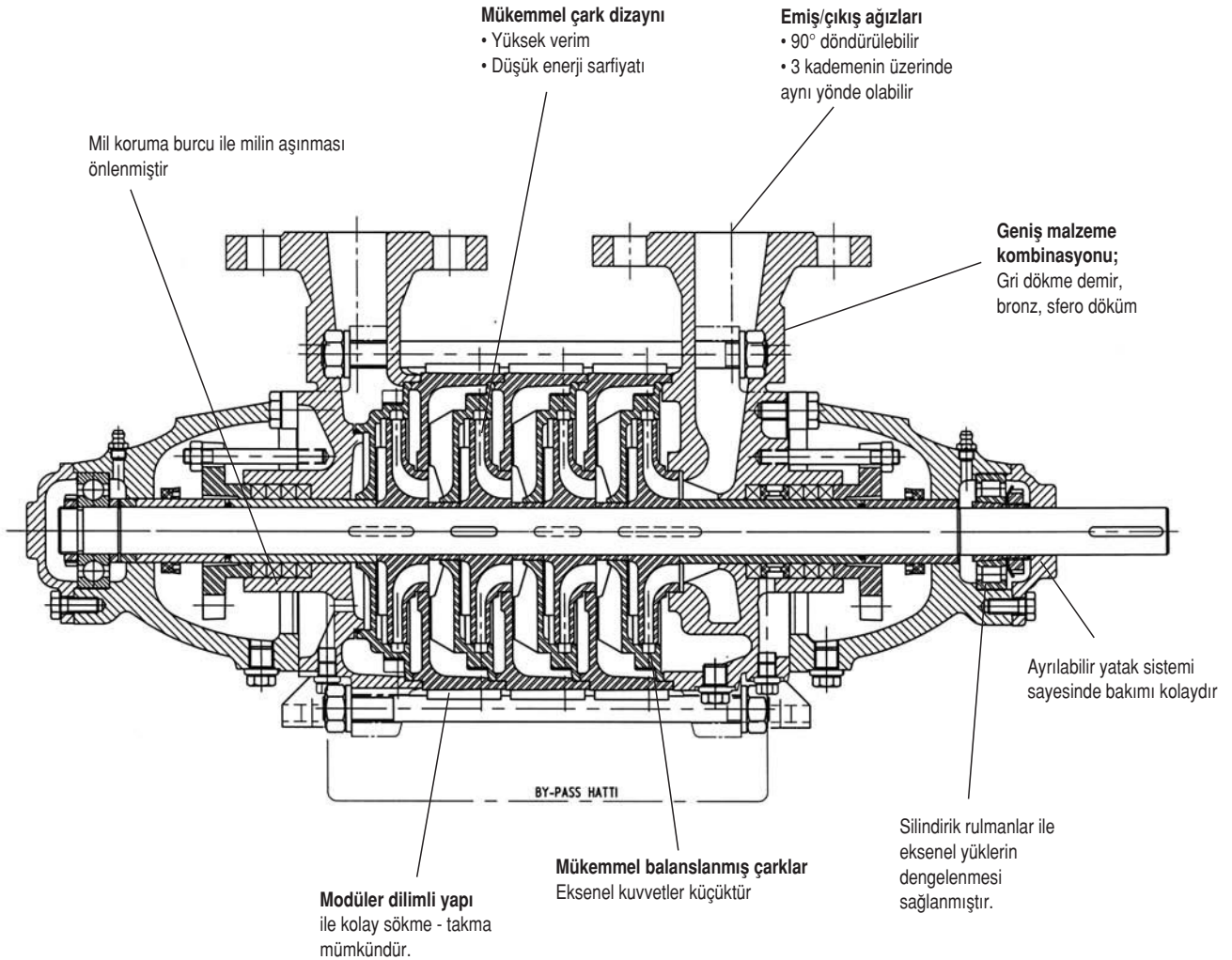

WKL 32

2900 d/dak

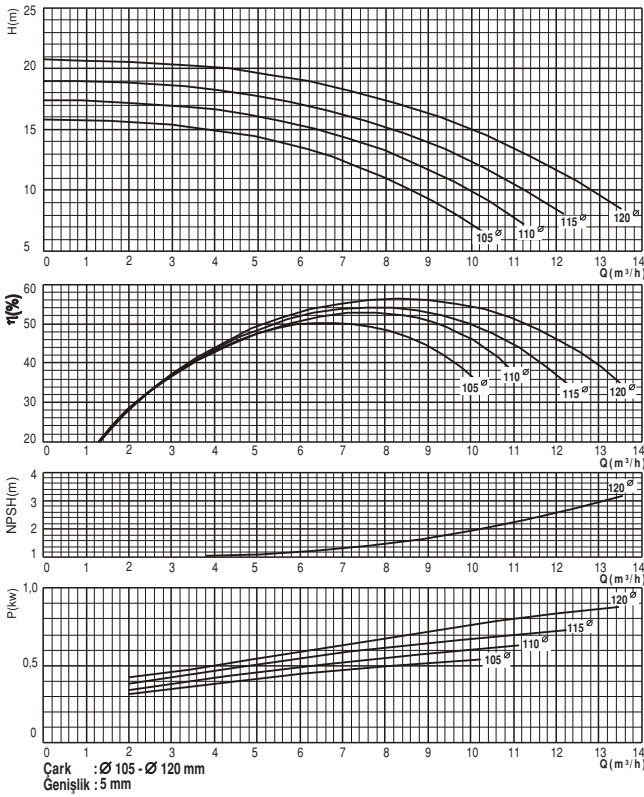

WKL 40

2900 d/dak

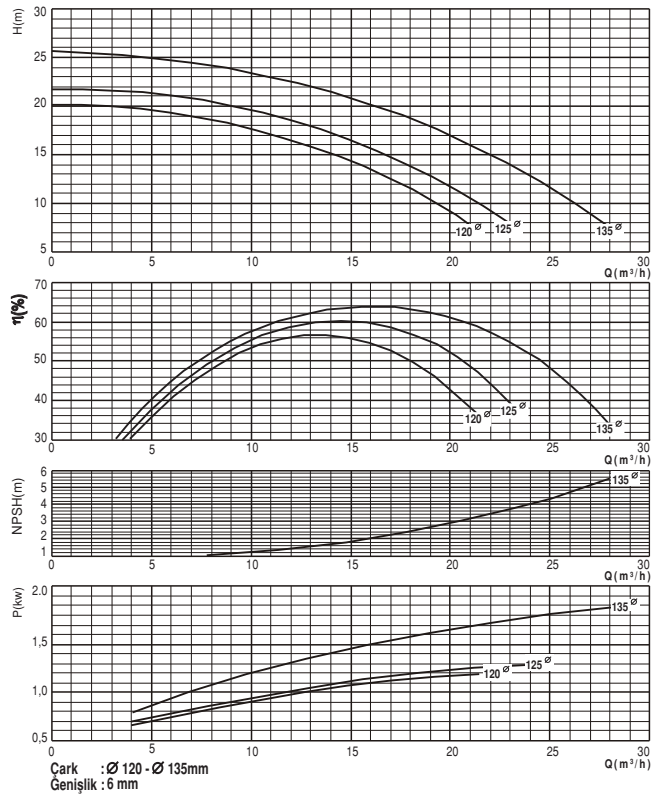

WKL 50

2900 d/dak

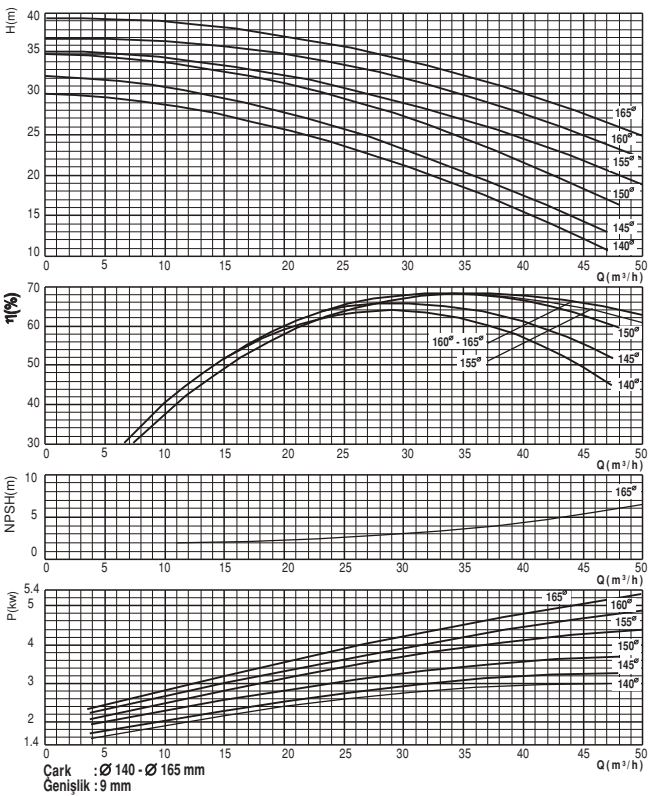

WKL 65

2900 d/dak

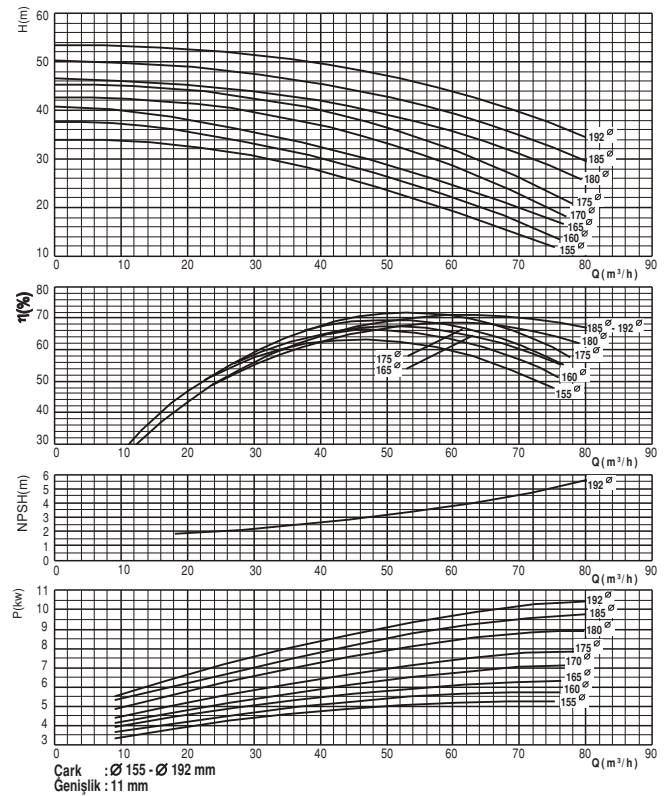

Not: Yukarıdaki performans eğrileri tek kademe için verilmiştir.

WKL 80

2900 d/dak

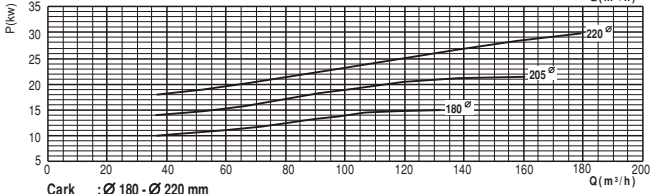
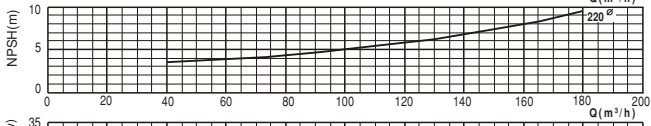
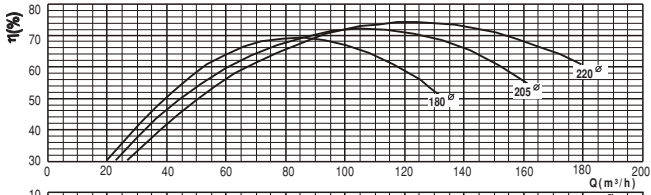
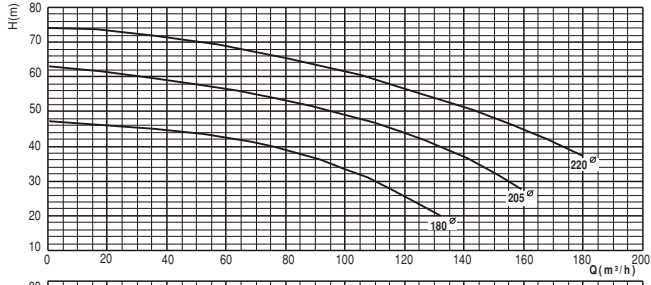

Çark : Ø 180 - Ø 220 mm
Genişlik : 17 mm

Not: Yukarıdaki performans eğrileri tek kademe için verilmiştir.

WKL 32

1450 d/dak

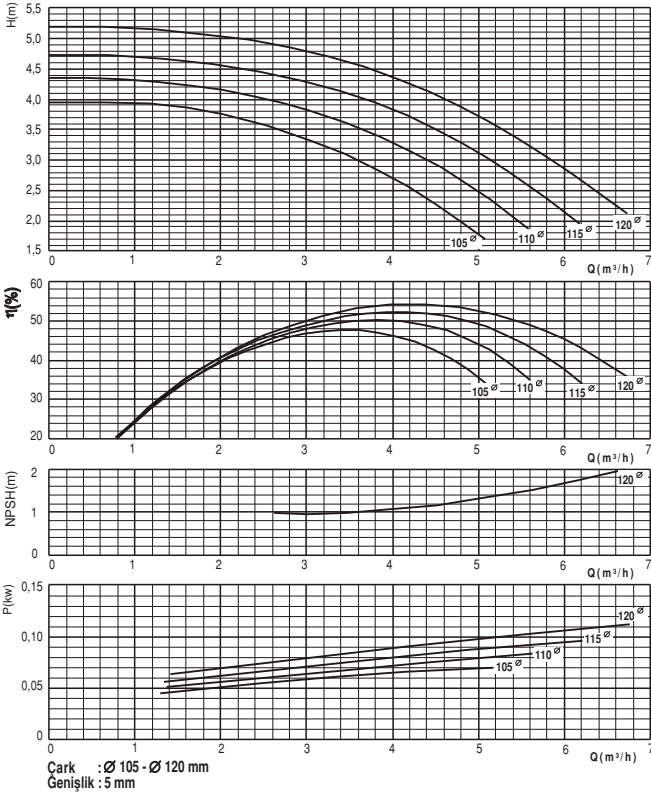

WKL 40

1450 d/dak

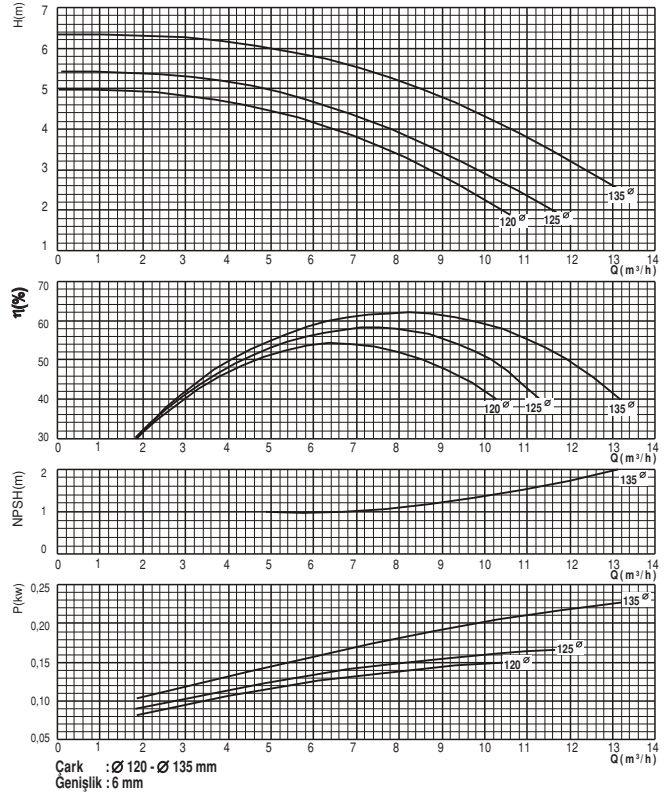

WKL 50

1450 d/dak

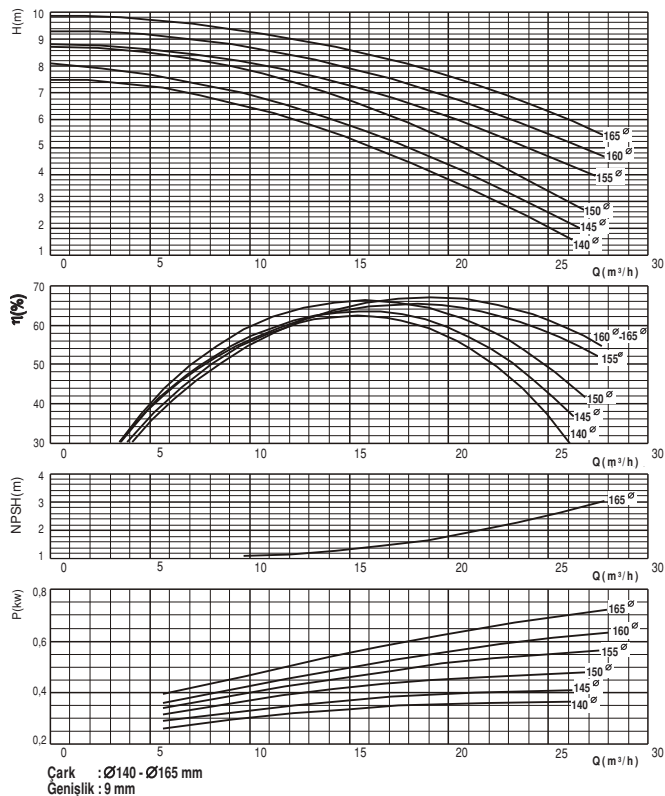

Not: Yukarıdaki performans eğrileri tek kademe için verilmiştir.

WKL 65

1450 d/dak

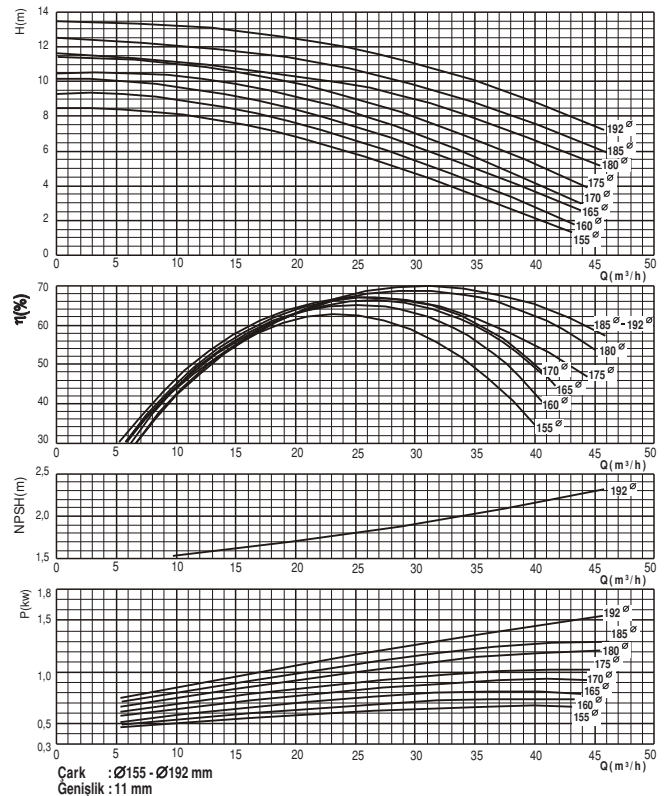

WKL 80

1450 d/dak

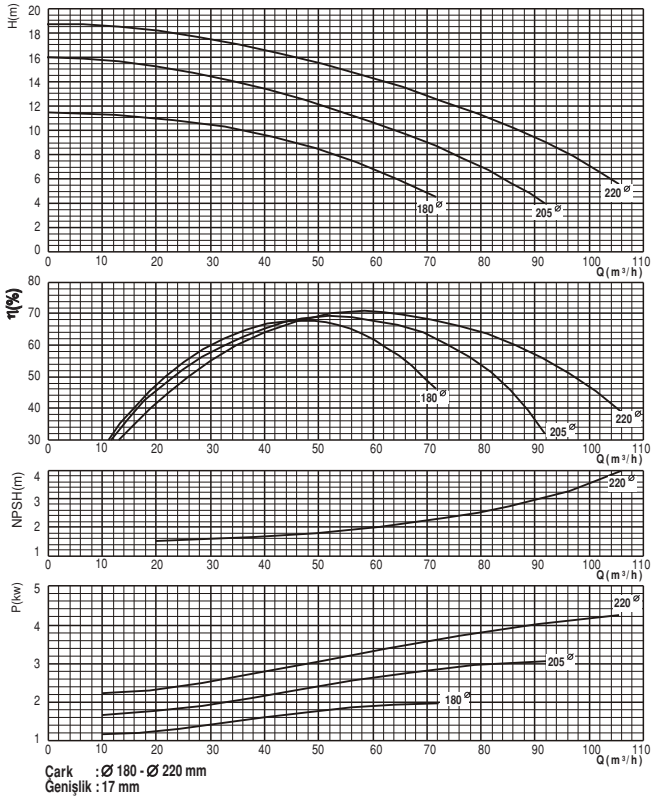

WKL 100

1450 d/dak

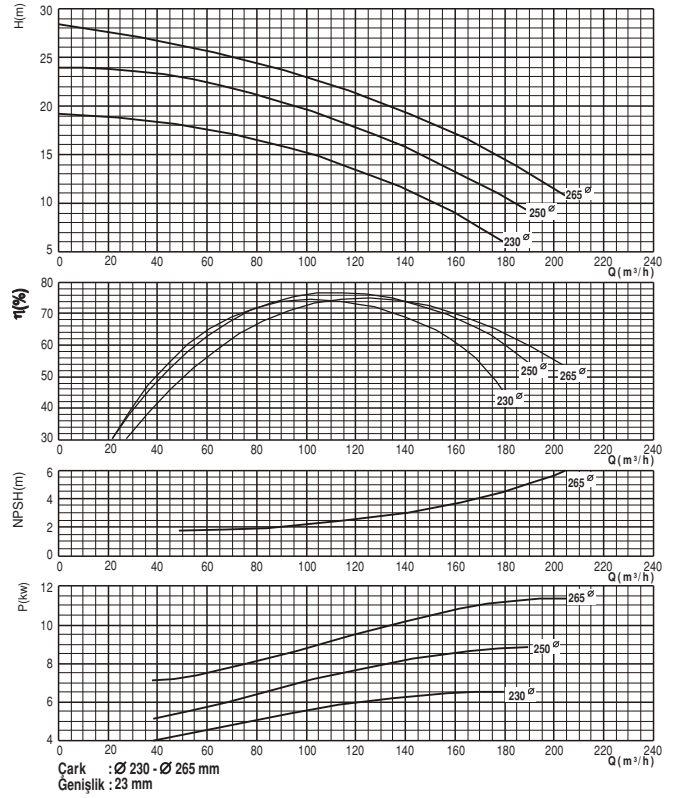

WKL 125

1450 d/dak

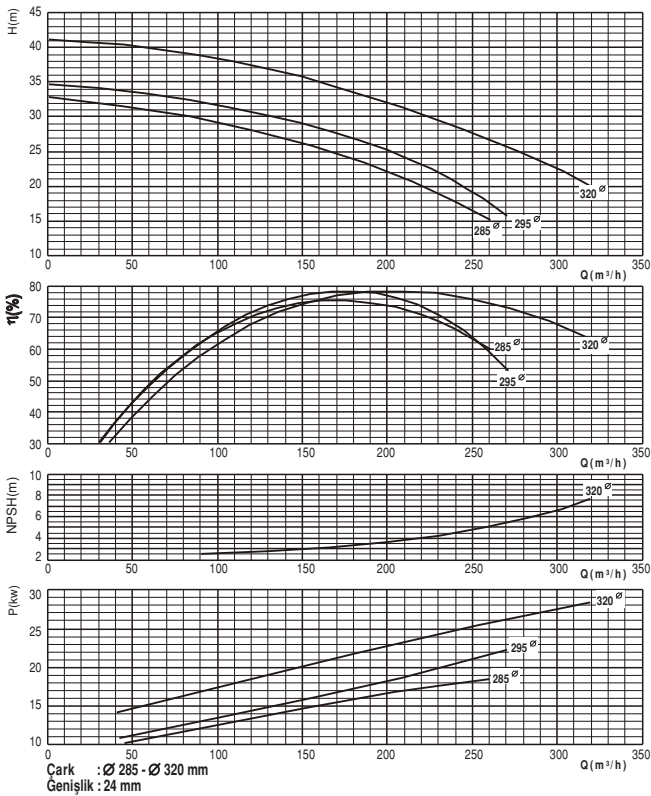

Not: Yukarıdaki performans eğrileri tek kademeye için verilmiştir.

WKL 150

1450 d/dak

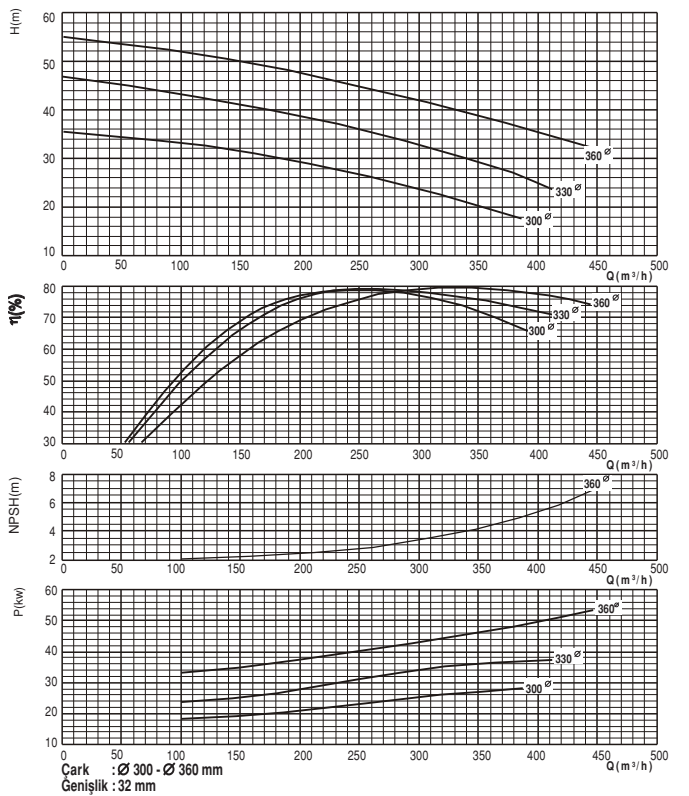

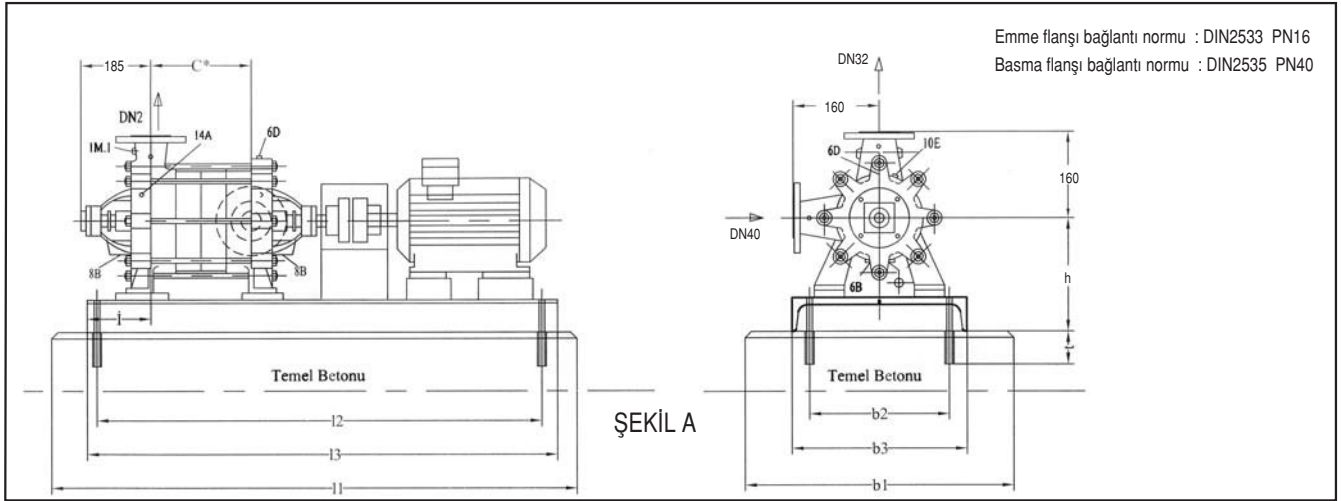
WKL 32

WKL	KW		IEC	L ₁	L ₂	L ₃	i	b ₁	b ₂	b ₃	h	fig 0 kg	fig 3 kg
	1450	2900											
32/01	0.12		63M	860	650	710	90	450	240	300	205	29	69
	0.18												70
	0.25												71
	0.37	0.55	80M										74
		0.75											76
32/02	0.12		63M	860	650	710	90	450	240	300	205	34	74
	0.18												75
	0.25												76
	0.37		71M										79
		0.75											81
		1.1	80M										83
		1.5											86
	2.2	90 L											
32/03	0.25		71M	860	650	710	90	450	240	300	205	39	80
	0.37												81
	0.55												80M
	0.75		89										
		1.5	90S										92
		2.2	90 L										95
	3.0	100 L	101										
32/04	0.25		71M	950	740	800	90	450	240	300	205	44	89
	0.37												90
	0.55												80M
	0.75		94										
		2.2	90 L										105
		3	100 L										111
		4	112M										118
			212										
32/05	0.25		71M	950	740	800	100	450	240	300	205	49	94
	0.37												95
	0.55												80M
	0.75		101										
		3	100L										120
		4	112M										127
		5.5	132S										137
	7.5	146											
32/06	0.55		80M	1050	840	900	100	450	240	300	205	54	108
	0.75												109
		3	100L										125
		4	112M										132
		5.5	132S										148
	7.5	157											

t: 250 mm
 fig 0: Çıplak Pompa
 fig 3: Pompa+Motor+Kaplın+Kaide
 Ankrj Saplamaları : M16X250

	Bağlantılar		WKL
	G ₁	G ₂	
Monometre Bağlantısı	1M.1	G	1/2"
Sızdırmazlık Sıvı Çıkışı	14 A	G	1/8"
Sızdırmazlık Sıvı Girişi	10 E	G	1/8"
Akışkan Drenajı	6 B	G	1/8"
Akışkan Doldurma ve Hava Alma	6 D	G	1/4"
Sızıntı Drenajı	8 B	G	1/2"

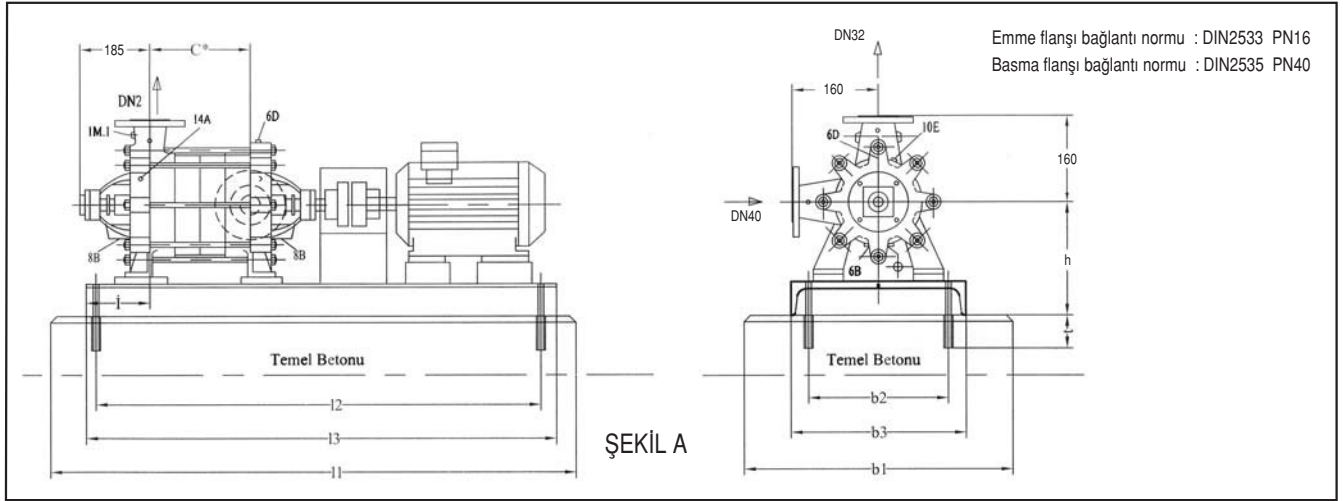
WKL 32

WKL	KW		IEC	L ₁	L ₂	L ₃	i	b ₁	b ₂	b ₃	h	fig	
	1450	2900										0	3
												kg	kg
32/07	0.55		80M	1050	840	900	100	450	240	300	205	59	113
	0.75												114
	1.1		112M	1150	940	1000					215	59	121
	4												143
	5.5												132S
7.5		162											
32/08	0.55		80M	1150	940	1000	100	450	240	300	235	64	122
	0.75												123
	1.1		112M	1150	940	1000					215	64	136
	4												158
	5.5												132S
7.5		177											
32/09	0.55		80M	1150	940	1000	100	450	240	300	205	69	127
	0.75												128
	1.1		112M	1270	1060	1120					215	69	137
	4												153
	5.5												132S
	7.5		178										
11		160M	1550	1340	1400	260	69	205					
15								214					
32/10	0.55		80M	1270	1060	1120	100	450	240	300	205	74	138
	0.75												139
	1.1		132S	1400	1190	1250					235	74	143
	5.5												175
	7.5												160M
	11		211										
15								220					
32/11	1.1		90S	1270	1060	1120	100	450	240	300	205	79	147
	1.5		90L										150
	5.5		132S	1450	1240	1300					235	79	181
	7.5												190
	11												160M
15		226											
32/12	1.1		90S	1400	1190	1250	100	450	240	300	205	84	158
	1.5		90L										161
	5.5		132S	1550	1340	1400					235	84	191
	7.5												200
	11												160M
15		231											

t: 250 mm
 fig 0: Çıplak Pompa
 fig 3: Pompa+Motor+Kaplın+Kaide
 Ankraj Saplamaları : M16X250

	Bağlantılar		WKL
	G ₁	ISO 228/1	
Monometre Bağlantısı	1M.1	G	1/2"
Sızdırmazlık Sıvı Çıkışı	14 A	G	1/8"
Sızdırmazlık Sıvı Girişi	10 E	G	1/8"
Akışkan Drenajı	6 B	G	1/8"
Akışkan Doldurma ve Hava Alma	6 D	G	1/4"
Sızıntı Drenajı	8 B	G	1/2"

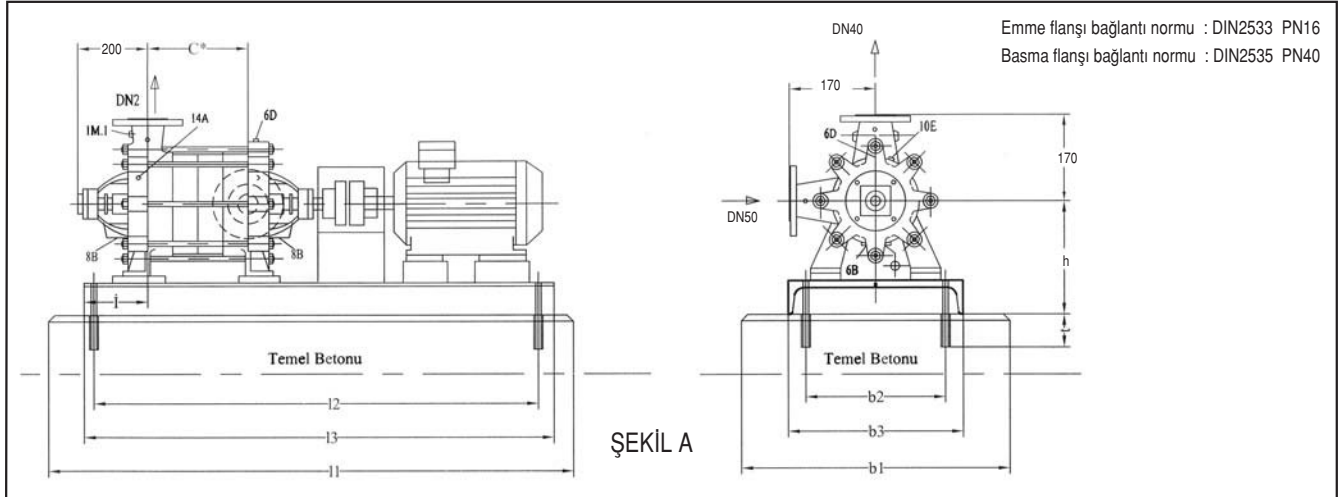
WKL 40

WKL	KW		IEC	L ₁	L ₂	L ₃	l	b ₁	b ₂	b ₃	h	fig 0 kg	fig 3 kg
40/01	0,12		63M	860	650	710	90	450	240	300	215	42	82
	0,18												82
		0,75	80M										87
		1,1											89
		1,5											91
	2,2	90L	94										
40/02	0,25		71M	860	650	710	90	450	240	300	215	47	88
	0,37												89
	0,55		80M										92
	0,75												93
		2,2	90L										103
		3	100L										109
	4	112M	116										
40/03	0,55		80M	950	740	800	90	450	240	300	215	52	101
	0,75												102
		3	100L										119
		4	112M										126
		5,5	132S										136
	7,5	145											
40/04	0,55		80M	950	740	800	100	450	240	300	215	57	106
	0,75												107
		1,1	90S										115
		4	112M										135
		5,5	132S										146
	7,5	155											
40/05	0,55		80M	1050	840	900	100	450	240	300	215	62	116
	0,75												117
		1,1	90S										120
		1,5	90L										123
		5,5	132S										146
		7,5											155
	11	160M	186										
	15		196										
40/06	1,1		90S	1150	940	1000	100	450	240	300	215	67	129
	1,5												132
	2,2		100L										143
	3												146
		5,5	132S										161
		7,5											170
		11	160M										195
		15											204

t: 250 mm

fig 0: Çıplak Pompa

fig 3: Pompa+Motor+Kaplın+Kaide

Ankraj Saplamaları : M16X250

	Bağlantılar		WKL 40
	G _s	ISO 228/1	
Monometre Bağlantısı	1M.1	G	1/2"
Sızdırmazlık Sıvı Çıkışı	14 A	G	1/8"
Sızdırmazlık Sıvı Girişi	10 E	G	1/8"
Akışkan Drenajı	6 B	G	1/8"
Akışkan Doldurma ve Hava Alma	6 D	G	3/8"
Sızıntı Drenajı	8 B	G	1/2"

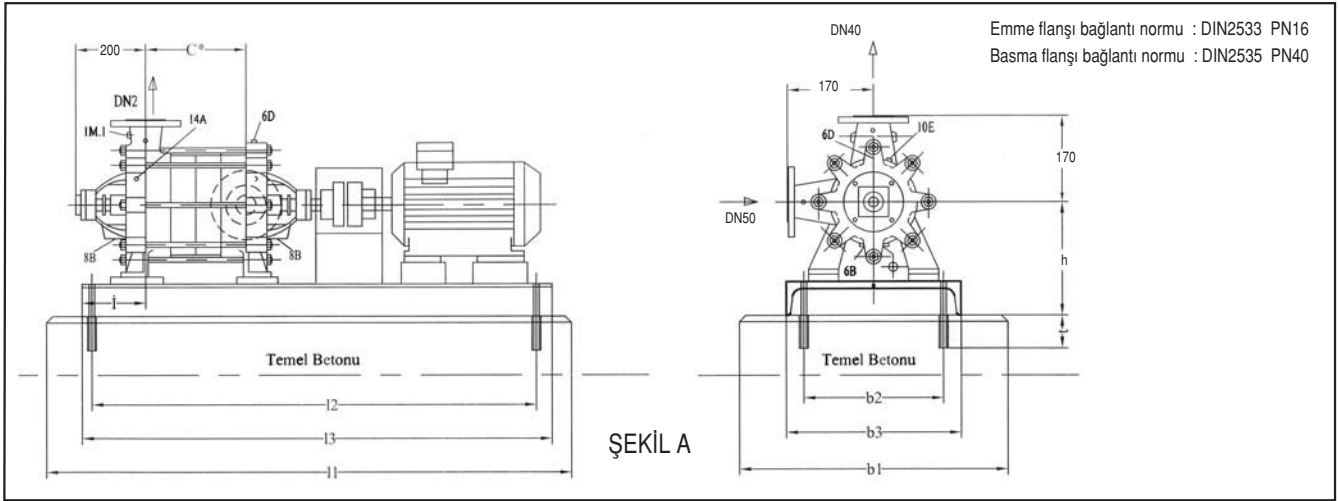
WKL 40

WKL	KW 1450 2900	IEC	L ₁	L ₂	L ₃	i	b ₁	b ₂	b ₃	h	fig 0 kg	fig 3 kg
40/7	1,1	90S	1150	940	1000	100	450	240	300	215	72	134
	1,5	90L										137
	2,2	100L	148									
	3		151									
	5,5	132S	169									
	7,5		178									
	11	160M	213									
15	221											
40/8	1,1	90S	1270	1060	1120	100	450	240	300	215	77	145
	1,5	90L										148
	2,2	100L	153									
	3		156									
	11	160M	195									
15	204											
40/9	1,5	90L	1270	1060	1120	100	450	240	300	215	82	153
	2,2	100L	161									
	3		164									
	11	160M	223									
	15		232									
18,5	160L	241										
40/10	1,5	90L	1350	1140	1200	100	450	240	300	215	87	161
	2,2	100L	169									
	3		172									
	11	160M	230									
	15		239									
18,5	160L	248										
40/11	1,5	90L	1400	1190	1250	100	450	240	300	215	92	169
	2,2	100L	176									
	3		179									
40/12	2,2	100L	1500	1290	1350	100	450	240	300	215	97	179
	3											186
	4	112M										193

t: 250 mm

fig 0: Çıplak Pompa

fig 3: Pompa+Motor+Kaplın+Kaide

Ankraj Saplamaları : M16X250

	Bağlantılar		WKL 40
	ISO 228/1	G=	
Monometre Bağlantısı	1M.1	G	1/2"
Sızdırmazlık Sıvı Çıkışı	14 A	G	1/8"
Sızdırmazlık Sıvı Girişi	10 E	G	1/8"
Akışkan Drenajı	6 B	G	1/8"
Akışkan Doldurma ve Hava Alma	6 D	G	3/8"
Sızıntı Drenajı	8 B	G	1/2"

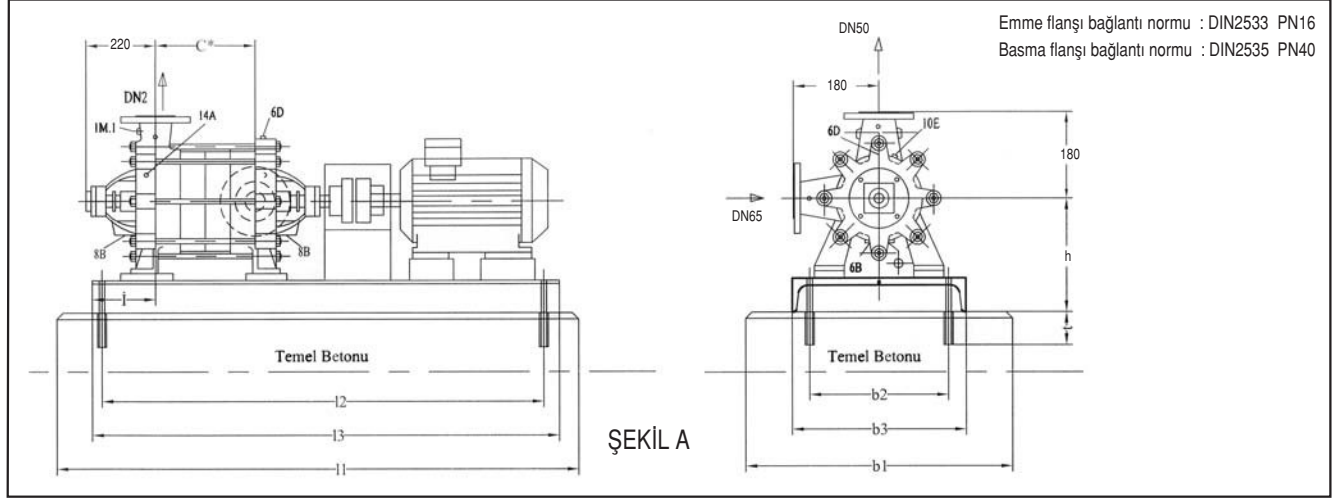
WKL 50

WKL	KW		IEC	L ₁	L ₂	L ₃	l	b ₁	b ₂	b ₃	h	fig 0 kg	fig 3 kg						
	1450	2900																	
50/01	0.25		71M	860	650	710	100	450	240	300	235	53	94						
	0.37												95						
	0.55												102						
	0.75		80M	950	740	800							103						
		3	100L										115						
		4	112M	1000	790	850							124						
		5.5	132S	1050	840	900							137						
	7.5	146																	
50/02	0.55		80M	950	740	800	112	450	240	300	235	63	112						
	0.75												113						
	1.1		90S	1000	790	850							118						
	1.5		90L										121						
		5.5	132S	1150	940	1000							151						
		7.5											160						
	11	186																	
	15	160M	1270	1060	1120	112	510	300	360	270	63	195							
50/03	1.1		90S	1050	840	900	112	450	240	300	235	73	131						
	1.5		90L										134						
	2.2		100L	1150	940	1000							143						
	3												146						
		11	160M	1350	1140	1200							112	510	300	360	270	73	199
		15											160L	208					
		18.5											160L	217					
	22	180M	1450	1240	1300	112	550	320	400	290	73	244							
50/04	1.5		90L	1150	940	1000	112	450	240	300	235	83	148						
	2.2		100L										163						
	3												166						
	4												173						
		11	160M	1350	1140	1200							112	510	300	360	270	83	209
		15											160L	218					
		18.5	160L	227															
		22	180M	1500	1290	1350							112	550	320	400	290	83	284
		30	200L	1550	1340	1400													352
	37	372																	
50/05	2.2		100L	1270	1060	1120	112	450	240	300	235	93	169						
	3												172						
	4		112M	179															
		11	160M	1400	1190	1250							112	550	300	360	270	93	219
		15											160L	228					
		18.5	160L	237															
		22	180M	1550	1340	1400							112	550	320	400	295	93	297
		30	200L	1600	1390	1450											315	93	365
	37	385																	

t: 250 mm

fig 0: Çıplak Pompa

fig 3: Pompa+Motor+Kaplın+Kaide

Ankraj Saplamaları : M16X250

	Bağlantılar		WKL
		G ₌ ISO 228/1	
Monometre Bağlantısı	1M.1	G	50
Sızdırmazlık Sıvı Çıkışı	14 A	G	1/8"
Sızdırmazlık Sıvı Girişi	10 E	G	1/8"
Akışkan Drenajı	6 B	G	3/8"
Akışkan Doldurma ve Hava Alma	6 D	G	3/8"
Sızıntı Drenajı	8 B	G	1/2"

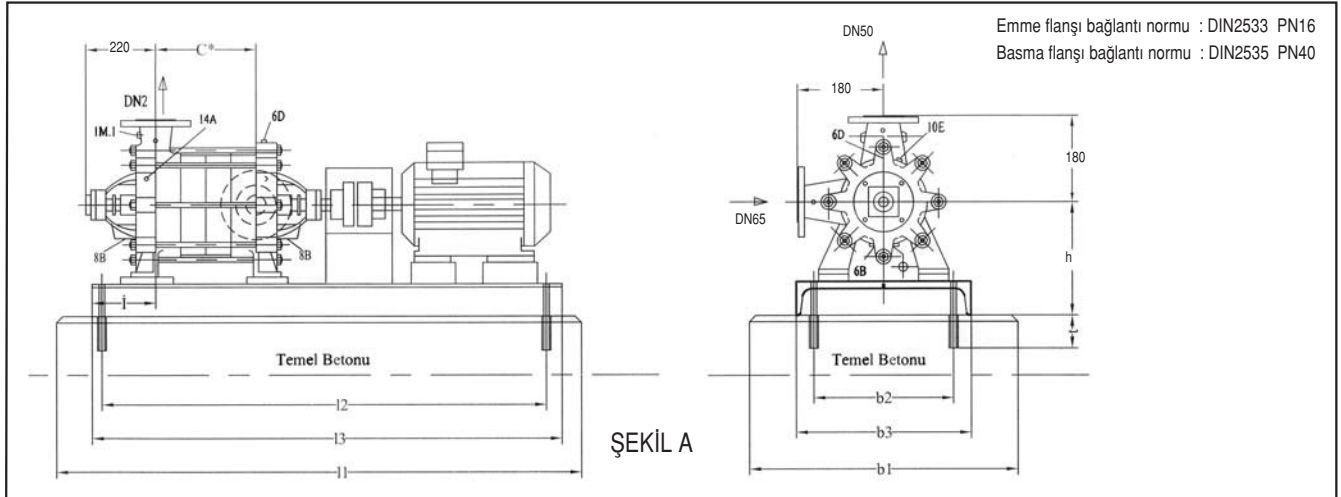
WKL 50

WKL	KW		IEC	L ₁	L ₂	L ₃	l	b ₁	b ₂	b ₃	h	fig 0 kg	fig 3 kg
	1450	2900											
50/06	2.2		100L	1270	1060	1120	112	450	240	300	235	103	179
	3												182
	4		112M										189
	5.5		132S										202
		18.5	160L										257
		22	180M										310
		30	200L										379
	37		399										
50/07	2.2		100L	1350	1140	1200	112	450	240	300	235	113	192
	3												195
	4		112M										202
	5.5		132S										215
		18.5	160L										270
		22	180M										324
		30	200L										393
		37											413
	45	225M	423										
50/08	2.2		100L	1350	1140	1200	112	450	240	300	235	123	202
	3												205
	4		112M										215
	5.5		132S										225
	7.5		132M										233
50/09	4		112M	1450	1240	1300	112	450	240	300	235	133	227
	5.5		132S										237
	7.5		132M										245
50/10	4		112M	1500	1290	1350	112	450	240	300	235	143	239
	5.5		132S										249
	7.5		132M										257
	11		160M										278

t: 250 mm

fig 0: Çıplak Pompa

fig 3: Pompa+Motor+Kaplin+Kaide

Ankraj Saplamaları : M16X250

	Bağlantılar		WKL
	G=	ISO 228/1	
Monometre Bağlantısı	1M.1	G	50
Sızdırmazlık Sıvı Çıkışı	14 A	G	1/2"
Sızdırmazlık Sıvı Girişi	10 E	G	1/8"
Akışkan Drenajı	6 B	G	3/8"
Akışkan Doldurma ve Hava Alma	6 D	G	3/8"
Sızıntı Drenajı	8 B	G	1/2"

WKL 65

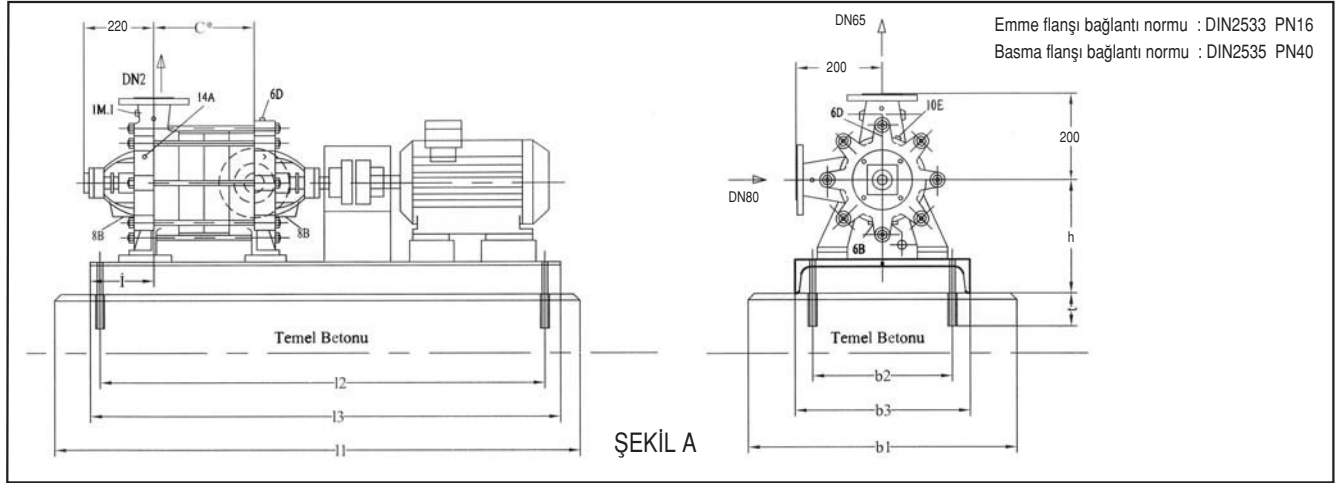

ŞEKİL A

WKL	KW		IEC	L ₁	L ₂	L ₃	l	b ₁	b ₂	b ₃	h	fig 0 kg	fig 3 kg	
	1450	2900												
65/01	0.55		80M	950	740	800	112	510	300	360	265	65	127	
	0.75												128	
	1.1												131	
	1.5												134	
	2.2		100L	1000	790	850					265	65	143	
	3												146	
		5.5											164	
		7.5											173	
	11	160M	1270	1060	1120	270	65	207						
	15							216						
65/02	1.5		90L	1050	840	900	112	510	300	360	265	82	151	
	2.2		100L										163	
	3		112M										166	
	4		112M	1150	940	1000					270	82	179	
		11	160M	1270	1060	1120							224	
		15	160L	1270	1060	1120							233	
		18.5	160L	1400	1190	1250					305	82	242	
	22	180M	1400	1190	1250	277								
65/03	2.2		100L	1150	940	1000	112	510	300	360	265	99	174	
	3												189	
	4												196	
	5.5												132S	214
	7.5		132M	1270	1060	1120					270	99	222	
		11	160M	1350	1140	1200							246	
		15	160M	1350	1140	1200					295	99	255	
		18.5	160L	1450	1240	1300							264	
		22	180M	1450	1240	1300							297	
		30	180M	1550	1340	1400					315	99	368	
	37	200L	1550	1340	1400	388								
65/04	2.2		100L	1270	1060	1120	112	510	300	360	265	116	199	
	3												214	
	4												112M	221
	5.5												132S	231
	7.5		132M	1400	1190	1250					270	116	239	
	11		160M	1400	1190	1250							271	
		22	180M	1500	1290	1350					295	116	317	
		30	180M	1500	1290	1350							388	
		37	200L	1600	1390	1450							408	
		45	225M	1550	1150	1400					710	500	560	325
65/05	4		112M	1270	1060	1120	112	510	300	360	265	133	216	
	5.5		132S	1350	1140	1200							253	
	7.5		132M	1350	1140	1200							261	
	11		160M	1450	1240	1300							291	
		30	200L	1600	1390	1450		315	133	405				
		37								425				
		45								225M	1600	1200	1450	450
		55								250M	1650	1250	1500	475

t: 320 mm

fig 0: Çıplak Pompa

fig 3: Pompa+Motor+Kaplin+Kaide

Ankraj Saplamları : M20X320

	Bağlantılar		WKL 65
	ISO 228/1	G ₁	
Monometre Bağlantısı	1M.1	G	1/2"
Sızdırmazlık Sıvı Çıkışı	14 A	G	1/8"
Sızdırmazlık Sıvı Girişi	10 E	G	1/8"
Akışkan Drenajı	6 B	G	3/8"
Akışkan Doldurma ve Hava Alma	6 D	G	3/8"
Sızıntı Drenajı	8 B	G	1/2"

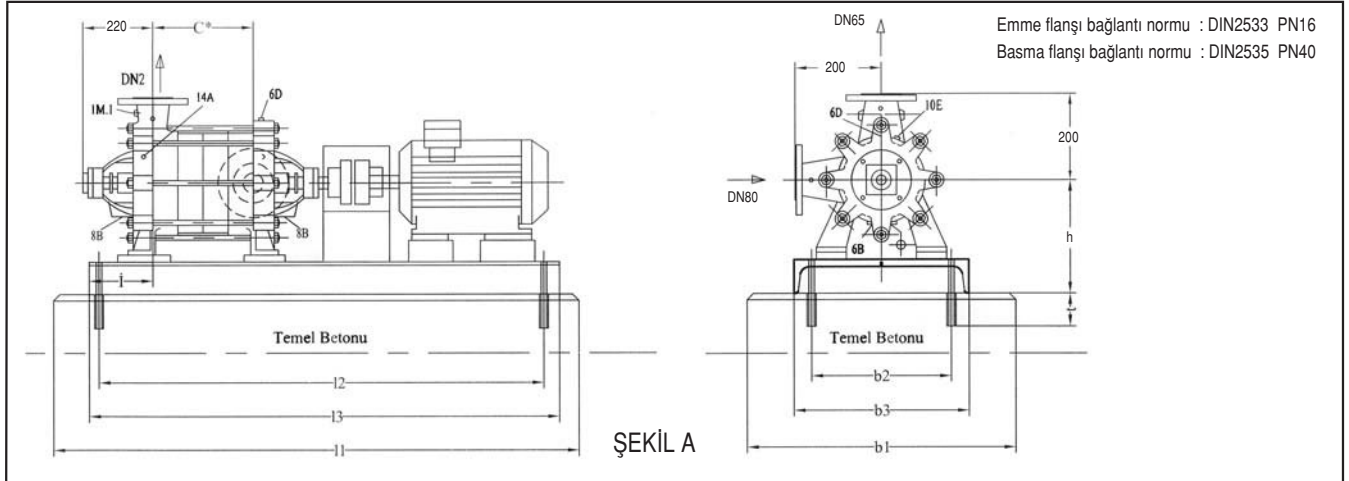
WKL 65

WKL	KW		IEC	L ₁	L ₂	L ₃	l	b ₁	b ₂	b ₃	h	fig 0	fig 3
	1450	2900										kg	kg
65/06	5.5		132S	1350	1140	1200	112	510	300	360	265	150	238
	7.5		132M	1400	1190	1250							242
	11		160M	1550	1340	1400						150	254
	15		160L										257
65/07	5.5		132S	1400	1190	1250	112	510	300	360	265	167	270
	7.5		132M	1450	1240	1300							276
	11		160M	1550	1340	1400						167	297
	15		160L										306
65/08	7.5		132M	1500	1290	1350	112	510	300	360	265	184	340
	11		160M	1650	1440	1500							184
	15		160L									291	
	18.5		180M	1750	1540	1600						184	309
65/09	7.5		132M	1550	1340	1400	112	510	300	360	265	201	316
	11		160M	1700	1490	1550							201
	15		160L									370	
	18.5		180M	1800	1590	1650						201	385
	22		180L										394
65/10	7.5		132M	1650	1440	1500	112	510	300	360	265	218	429
	11		160M	1750	1540	1600							218
	15		160L									346	
	18.5		180M	1850	1640	1700						218	359
	22		180L										369

t: 320 mm

fig 0: Çıplak Pompa

fig 3: Pompa+Motor+Kaplin+Kaide

Ankraj Saplamaları : M20X320

	Bağlantılar		WKL
	G=	ISO 228/1	
Monometre Bağlantısı	1M.1	G	1/2"
Sızdırmazlık Sıvı Çıkışı	14 A	G	1/8"
Sızdırmazlık Sıvı Girişi	10 E	G	1/8"
Akışkan Drenajı	6 B	G	3/8"
Akışkan Doldurma ve Hava Alma	6 D	G	3/8"
Sızıntı Drenajı	8 B	G	1/2"

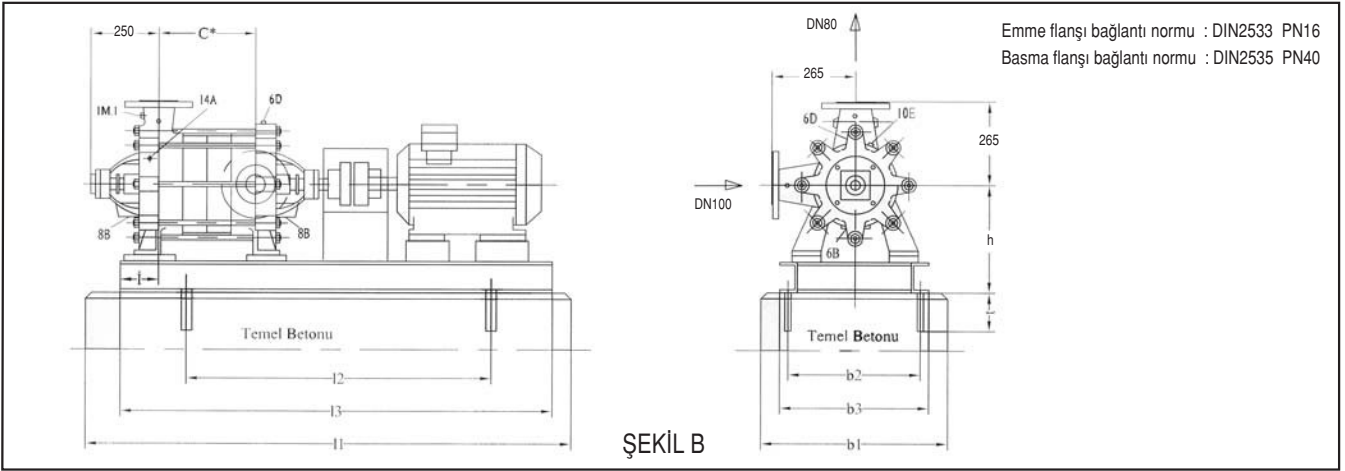
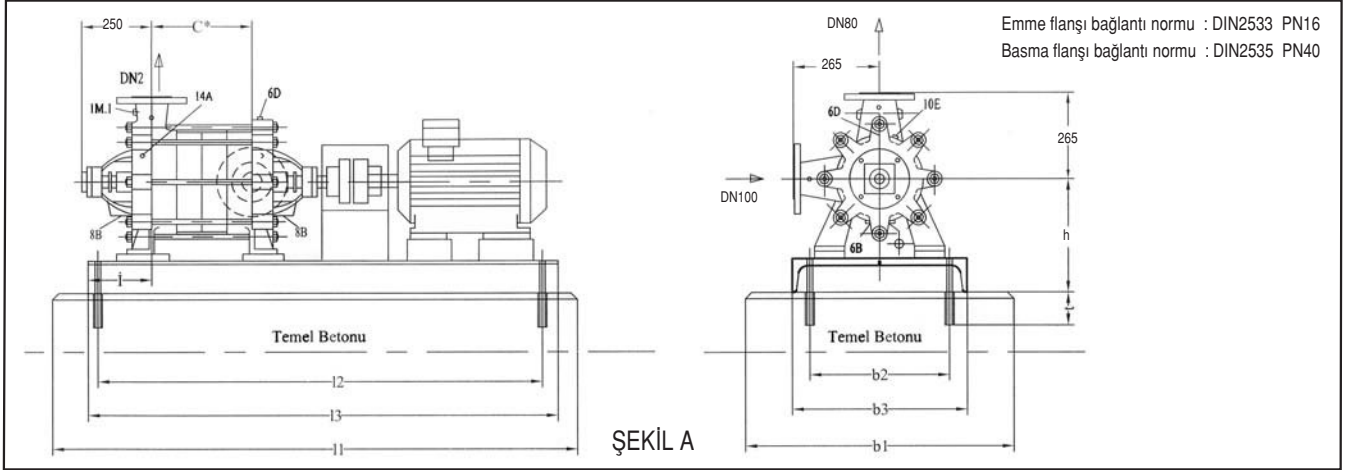
WKL 80

WKL	KW		FIG	IEC	L ₁	L ₂	L ₃	i	b ₁	b ₂	b ₃	h	fig 0 kg	fig 3 kg
	1450	2900												
80/01	2.2		A	100L	1050	840	900	112	550	320	400	325	135	226
	3		A	100L	1050	840	900		550	320	400	325	135	229
	4		A	112M	1050	840	900		550	320	400	325	135	236
	5.5		A	132S	1100	890	950		550	320	400	325	135	250
		15	A	160M	1270	1060	1120		550	320	400	325	135	300
		18.5	A	160L	1270	1060	1120		550	320	400	325	135	309
		22	A	180M	1270	1060	1120		550	320	400	325	135	336
		30	A	200L	1350	1140	1200		550	320	400	325	135	391
80/02		37	A	200L	1350	1140	1200	550	320	400	325	135	411	
	3		A	100L	1100	890	950	112	550	320	400	325	162	260
	4		A	112M	1100	890	950		550	320	400	325	162	267
	5.5		A	132S	1150	940	1000		550	320	400	325	162	280
	7.5		A	132M	1200	990	1050		550	320	400	325	162	292
	11		A	160M	1300	1090	1150		550	320	400	325	162	323
		22	A	180M	1450	1240	1300		550	320	400	325	162	341
		30	A	200L	1450	1240	1300		550	320	400	325	162	426
		37	A	200L	1450	1240	1300		550	320	400	325	162	446
		45	B	225M	1500	1050	1350		730	540	580	325	162	440
	55	B	250M	1600	1150	1450	790		600	640	390	162	495	
	75	B	280S	1650	1200	1500	870	670	720	400	162	825		

t: 320 mm

fig 0: Çıplak Pompa

fig 3: Pompa+Motor+Kaplin+Kaide

Ankraj Saplamları : M20X320

	Bağlantılar		WKL
	G _m	ISO 228/1	
Monometre Bağlantısı	1M.1	G	1/2"
Sızdırmazlık Sıvı Çıkışı	14 A	G	3/8"
Sızdırmazlık Sıvı Girişi	10 E	G	3/8"
Akışkan Drenajı	6 B	G	1/2"
Akışkan Doldurma ve Hava Alma	6 D	G	1/2"
Sızıntı Drenajı	8 B	G	1/2"

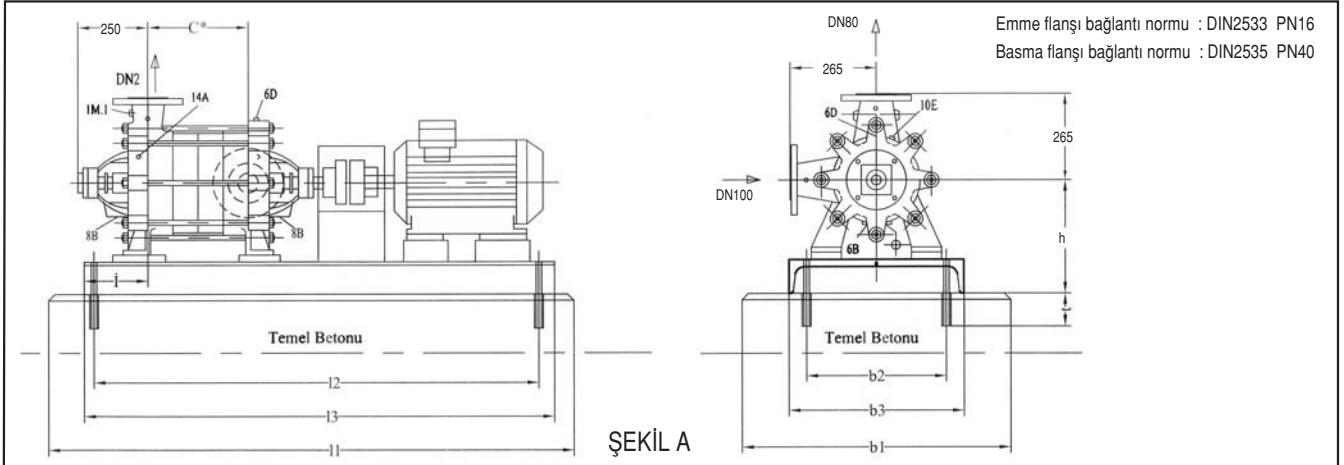
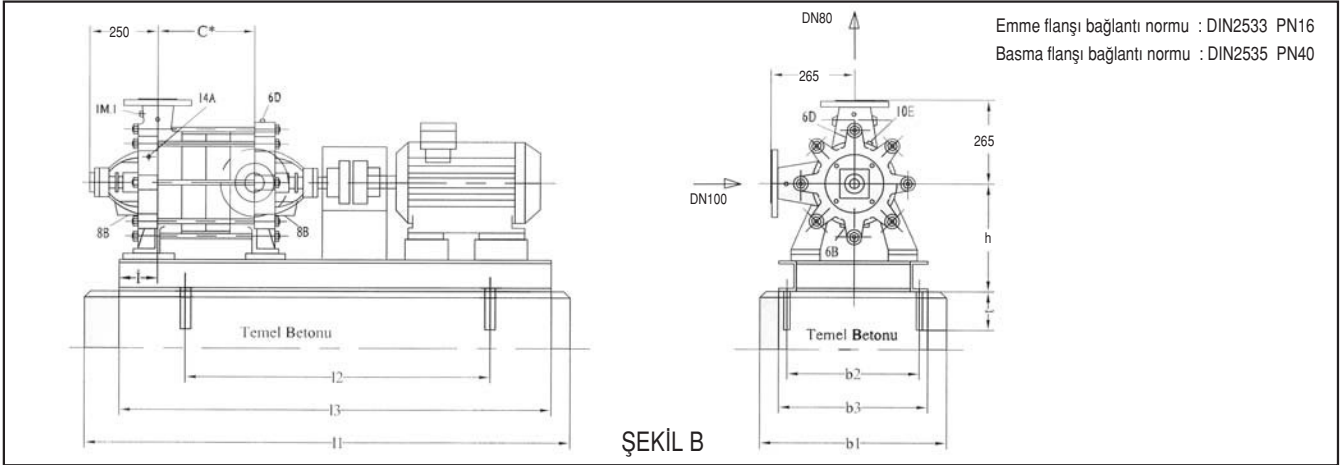
WKL 80

ŞEKİL A

ŞEKİL B

WKL	KW		FIG	IEC	L ₁	L ₂	L ₃	i	b ₁	b ₂	b ₃	h	fig 0 kg	fig 3 kg
	1450	2900												
80/03	5.5		A	132S	1250	1040	1100	112	550	320	400	325	189	315
	7.5		A	132M	1250	1040	1100		550	320	400	325	189	323
	11		A	160M	1400	1190	1250		550	320	400	325	189	358
	15		A	160L	1450	1240	1300		550	320	400	325	189	374
		45	B	225M	1500	1050	1350	125	730	540	580	325	189	465
		55	B	250M	1600	1150	1450		790	600	640	370	189	525
		75	B	280S	1700	1250	1550		870	670	720	400	189	850
		90	B	280M	1700	1250	1550		870	670	720	400	189	915
	110	B	315S	1800	1350	1650	880	690	730	455	189	1065		
80/04	7.5		A	132M	1350	1140	1200	112	550	320	400	325	216	357
	11		A	160M	1500	1290	1350		550	320	400	325	216	389
	15		A	160L	1500	1290	1350		550	320	400	325	216	401
	18.5		A	180M	1550	1340	1400		550	320	400	325	216	433
		75	B	280S	1800	1350	1650	125	860	670	710	380	216	875
		90	B	280M	1800	1350	1650		860	670	710	400	216	945
		110	B	315S	1850	1400	1700		940	740	790	455	216	1095
		132	B	315M	1900	1450	1750		940	740	790	455	216	1200
	160	B	315L	1900	1450	1750	940	740	790	455	216	1310		
80/05	11		A	160M	1550	1340	1400	112	550	320	400	325	243	423
	15		A	160L	1600	1390	1450		550	320	400	325	243	436
	18.5		A	180M	1650	1200	1500		550	320	400	325	243	467
	22		A	180L	1650	1440	1500		550	320	400	325	243	477
	30		A	200L	1650	1440	1500		550	320	400	325	243	514
		90	B	280M	1850	1400	1700	125	870	680	720	420	243	965
		110	B	315S	1950	1500	1800		940	740	790	455	243	1125
		132	B	315M	1950	1500	1800		940	740	790	455	243	1140
		160	B	315M	1950	1500	1800		940	740	790	455	243	1335
		160	B	315M	1950	1500	1800		940	740	790	455	243	1335

t: 320 mm

fig 0: Çıplak Pompa

fig 3: Pompa+Motor+Kaplın+Kaide

Ankraj Saplamaları : M20X320

	Bağlantılar		WKL
	G ₁	ISO 228/1	
Monometre Bağlantısı	1M.1	G	1/2"
Sızdırmazlık Sıvı Çıkışı	14 A	G	3/8"
Sızdırmazlık Sıvı Girişi	10 E	G	3/8"
Akışkan Drenajı	6 B	G	1/2"
Akışkan Doldurma ve Hava Alma	6 D	G	1/2"
Sızıntı Drenajı	8 B	G	1/2"

WKL 80

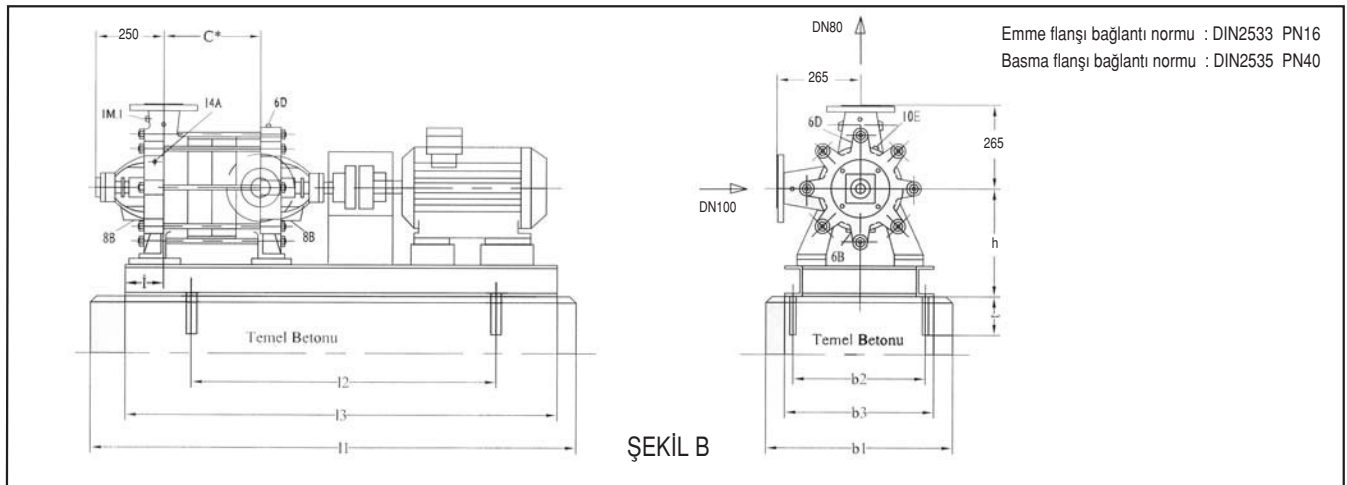
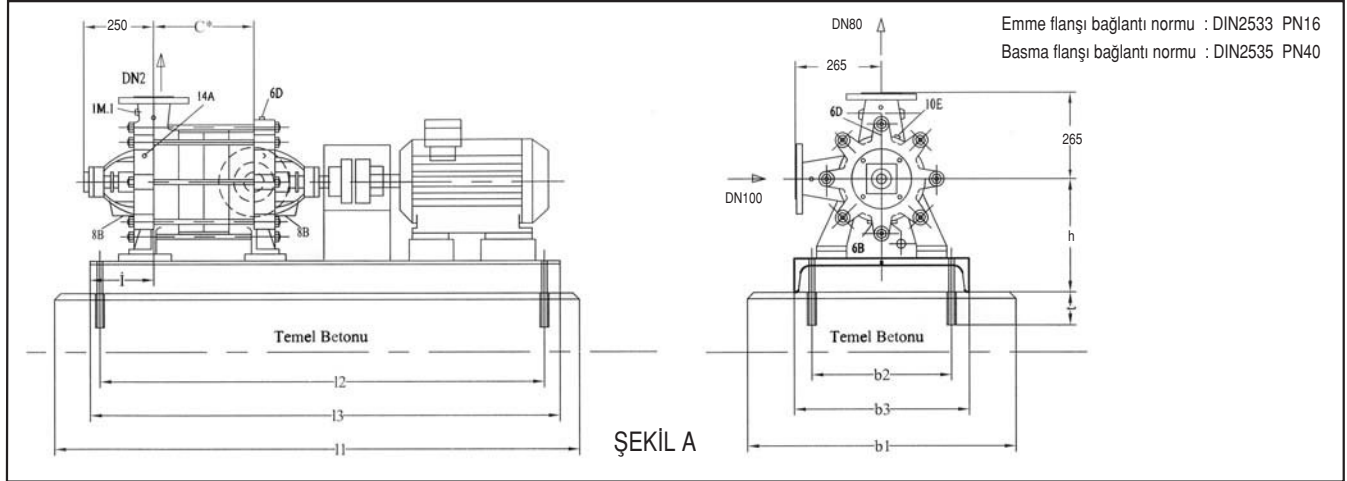

WKL	KW 1450	FIG	IEC	L ₁	L ₂	L ₃	i	b ₁	b ₂	b ₃	h	fig 0 kg	fig 3 kg
80/06	15	A	160L	1700	1490	1550	112	550	320	400	325	270	475
	18.5	A	180M	1750	1540	1600		550	320	400	325	270	507
	22	A	180L	1750	1540	1600		550	320	400	325	270	517
	30	A	200L	1750	1540	1600		550	320	400	325	270	554
80/07	15	A	160L	1750	1540	1600	112	550	320	400	325	297	506
	18.5	A	180M	1800	1590	1650		550	320	400	325	297	538
	22	A	180L	1800	1590	1650		550	320	400	325	297	548
	30	A	200L	1850	1640	1700		550	320	400	325	297	588
	37	B	225S	1900	1450	1750	125	730	540	580	365	297	615
80/08	18.5	A	180M	1900	1690	1750	112	550	320	400	325	324	572
	22	A	180L	1900	1690	1750		550	320	400	325	324	582
	30	A	200L	1950	1740	1800		550	320	400	325	324	623
	37	B	225S	1900	1450	1750	125	730	540	580	365	324	640
80/09	22	A	180L	2000	1790	1850	112	550	320	400	325	351	616
	30	A	200L	2000	1790	1850		550	320	400	325	351	653
	37	B	225S	2000	1550	1850	125	730	540	580	365	351	670
	45	B	225M	2100	1650	1950		730	540	580	365	351	715

t: 320 mm

fig 0: Çıplak Pompa

fig 3: Pompa+Motor+Kaplin+Kaide

Ankraj Saplamaları : M20X320

	Bağlantılar	G=	WKL
		ISO 228/1	80
Monometre Bağlantısı	1M.1	G	1/2"
Sızdırmazlık Sıvı Çıkışı	14 A	G	3/8"
Sızdırmazlık Sıvı Girişi	10 E	G	3/8"
Akışkan Drenajı	6 B	G	1/2"
Akışkan Doldurma ve Hava Alma	6 D	G	1/2"
Sızıntı Drenajı	8 B	G	1/2"

WKL 80

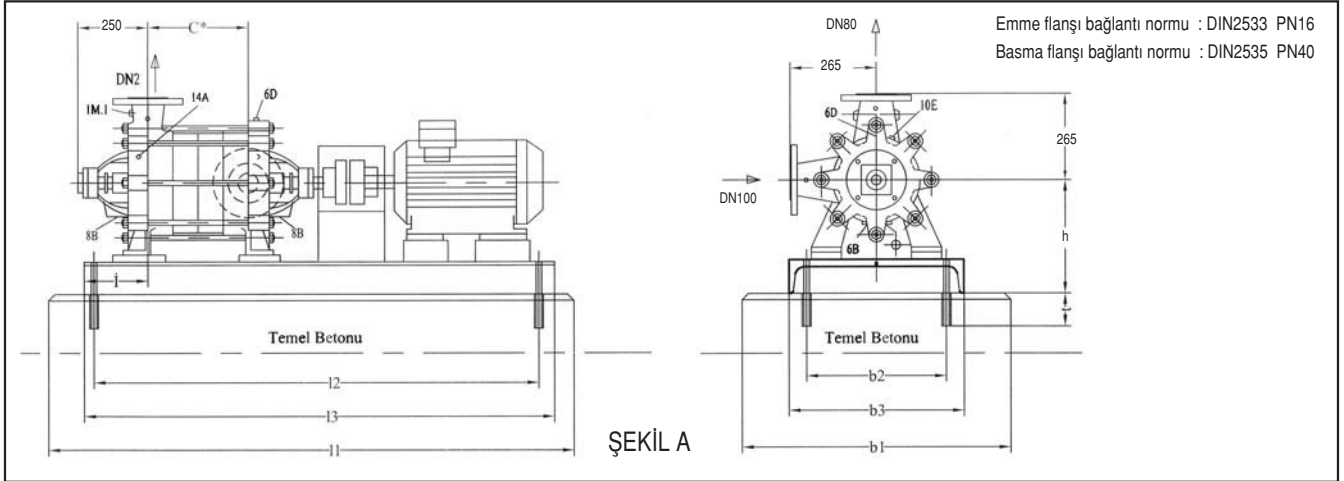

ŞEKİL A

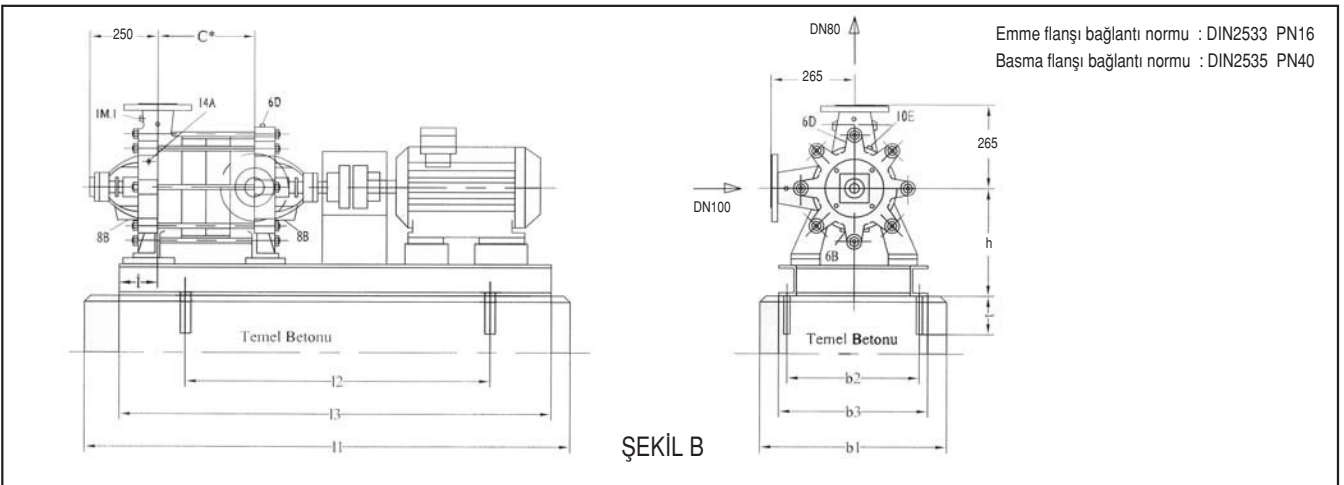

ŞEKİL B

WKL	KW 1450	FIG	IEC	L ₁	L ₂	L ₃	i	b ₁	b ₂	b ₃	h	fig 0 kg	fig 3 kg
80/10	22	A	180L	2050	1840	1900	112	550	320	400	325	378	642
	30	A	200L	2100	1890	1950		550	320	400	325	378	683
	37	B	225S	2100	1650	1950	125	730	540	580	365	378	732
	45	B	225M	2150	1700	2000		730	540	580	365	378	740
80/11	30	A	200L	2150	1940	2000	112	550	320	400	325	405	714
	37	B	225S	2250	1800	2100	125	730	540	580	365	405	730
	45	B	225M	2250	1800	2100		730	540	580	365	405	770
	55	B	250M	2250	1800	2100		790	600	640	390	405	800
80/12	30	A	200L	2250	2040	2100	112	550	320	400	325	432	748
	37	B	225S	2250	1800	2100	125	730	540	580	365	432	755
	45	B	225M	2350	1900	2200		730	540	580	365	432	800
	55	B	250M	2350	1900	2200		790	600	640	390	432	830
80/13	37	B	225S	2350	1900	2200	125	730	540	580	365	459	785
	45	B	225M	2350	1900	2200		730	540	580	365	459	825
	55	B	250M	2450	2000	2300		790	600	640	390	459	860
	75	B	280S	2550	2100	2400		870	670	720	420	459	1185

t: 320 mm

fig 0: Çıplak Pompa

fig 3: Pompa+Motor+Kaplin+Kaide

Ankraj Saplamaları : M20X320

	Bağlantılar		WKL 80
	G _e	ISO 228/1	
Monometre Bağlantısı	1M.1	G	1/2"
Sızdırmazlık Sıvı Çıkışı	14 A	G	3/8"
Sızdırmazlık Sıvı Girişi	10 E	G	3/8"
Akışkan Drenajı	6 B	G	1/2"
Akışkan Doldurma ve Hava Alma	6 D	G	1/2"
Sızıntı Drenajı	8 B	G	1/2"

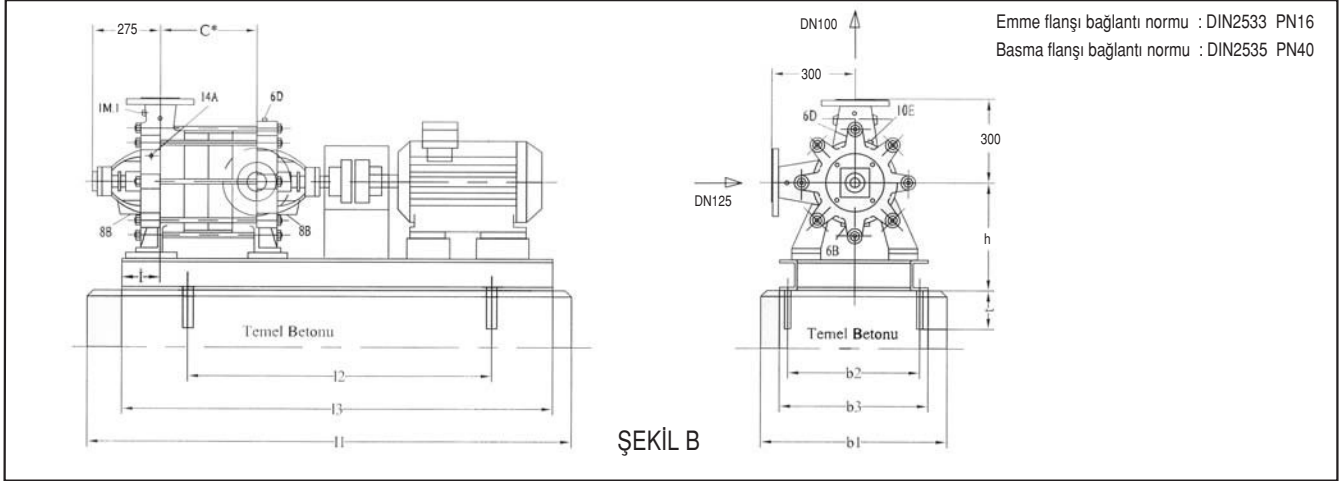
WKL 100

WKL	KW 1450	IEC	L ₁	L ₂	L ₃	i	b ₁	b ₂	b ₃	h	fig 0 kg	fig 3 kg
100/01	5.5	132S	1200	750	1050	135	730	540	580	330	150	260
	7.5	132M	1200	750	1050		730	540	580	330	150	280
	11	160M	1300	850	1150		730	540	580	330	150	290
	15	160L	1300	850	1150		730	540	580	330	150	300
100/02	11	160M	1400	950	1250		730	540	580	330	210	350
	15	160L	1400	950	1250		730	540	580	330	210	360
	18.5	180M	1450	1000	1300		730	540	580	350	210	400
	22	180L	1450	1000	1300		730	540	580	350	210	410
	30	200L	1500	1050	1350		750	540	600	350	210	460
100/03	18.5	180M	1550	1100	1400		750	540	600	350	270	470
	22	180L	1550	1100	1400		750	540	600	350	270	475
	30	200L	1600	1150	1450		750	540	600	350	270	530
	37	225S	1670	1220	1520		750	540	600	350	270	580
100/04	30	200L	1750	1300	1600		750	540	600	370	330	595
	37	225S	1750	1300	1600		750	540	600	370	330	650
	45	225M	1800	1350	1650		750	540	600	370	330	710
	55	250M	1920	1470	1770		840	630	690	370	330	725
100/05	37	225S	1900	1450	1750		750	540	600	370	390	720
	45	225M	1900	1450	1750		750	540	600	370	390	760
	55	250M	1950	1500	1800		840	630	690	370	390	800
	75	280S	2100	1650	1950		910	700	760	420	390	1150
100/06	45	225M	2000	1550	1850		750	540	600	370	450	830
	55	250M	2150	1700	2000		840	630	690	370	450	860
	75	280S	2150	1700	2000		910	700	760	420	450	1200
	55	250M	2150	1700	2000		840	630	690	420	510	920
100/07	75	280S	2250	1800	2100		910	700	760	420	510	1275
	90	280M	2300	1850	2150		910	700	760	420	510	1450
	75	280S	2300	1850	2150		910	700	760	420	570	1330
100/08	90	280M	2300	1850	2150	910	700	760	420	570	1510	
	110	315S	2350	1900	2200	910	700	760	420	570	1575	
	75	280S	2450	2000	2300	910	700	760	420	630	1390	
100/09	90	280M	2500	2050	2350	910	700	760	420	630	1570	
	110	315S	2550	2100	2400	960	750	810	420	630	1650	

t: 320 mm

fig 0: Çıplak Pompa

fig 3: Pompa+Motor+Kaplin+Kaide

Ankraj Saplamaları : M20X320

	Bağlantılar		WKL 100
	G=	ISO 228/1	
Monometre Bağlantısı	1M.1	G	1/2"
Sızdırmazlık Sıvı Çıkışı	14 A	G	3/8"
Sızdırmazlık Sıvı Girişi	10 E	G	3/8"
Akışkan Drenajı	6 B	G	1/2"
Akışkan Doldurma ve Hava Alma	6 D	G	1/2"
Sızıntı Drenajı	8 B	G	1/2"

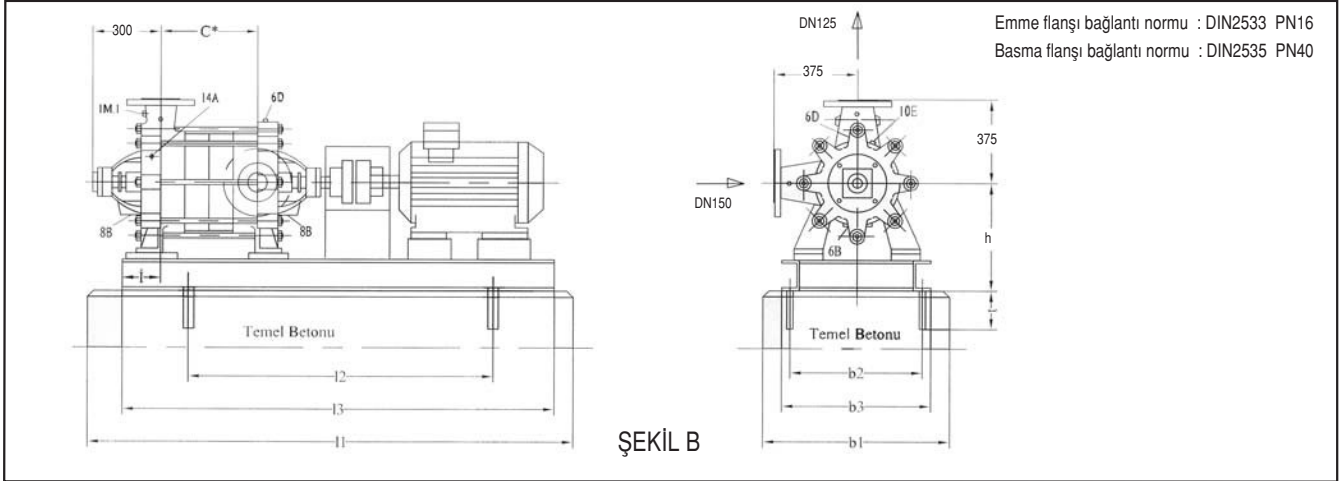
WKL 125

ŞEKİL B

WKL	KW 1450	IEC	L ₁	L ₂	L ₃	l	b ₁	b ₂	b ₃	h	fig 0 kg	fig 3 kg
125/01	15	160L	1450	1000	1300	145	840	640	690	420	232	420
	18.5	180M	1450	1000	1300		840	640	690	420	232	445
	22	180L	1500	1050	1350		840	640	690	420	232	450
	30	200L	1550	1100	1400		840	640	690	420	232	500
125/02	18.5	180M	1550	1100	1400		840	640	690	420	346	560
	22	180L	1550	1100	1400		840	640	690	420	346	570
	30	200L	1600	1150	1450		840	640	690	420	346	620
	37	225S	1700	1250	1550		840	620	690	420	346	660
	45	225M	1700	1250	1550		840	640	690	420	346	720
	55	250M	1750	1300	1600		870	670	720	420	346	750
125/03	75	280S	1820	1370	1670		870	670	720	440	346	1100
	37	225S	1830	1380	1680		840	640	690	420	460	790
	45	225M	1850	1400	1700		840	640	690	420	460	835
	55	250M	1900	1450	1750		870	670	720	440	460	870
	75	280S	1950	1500	1800		870	670	720	440	460	1210
	90	280M	2000	1550	1850		870	670	720	440	460	1375
125/04	110	315S	2050	1600	1900		970	770	820	455	460	1500
	55	250M	2000	1550	1850		870	670	720	440	574	990
	75	280S	2050	1600	1900		870	670	720	440	574	1320
	90	280M	2100	1650	1950		870	670	720	440	574	1490
	110	315S	2150	1700	2000		970	770	820	455	574	1600
	132	315M	2200	1750	2050		970	770	820	455	574	1700
125/05	160	315M	2200	1750	2050		970	770	820	455	574	1800
	75	280S	2200	1750	2050		870	670	720	440	688	1450
	90	280M	2250	1800	2100		870	670	720	440	688	1620
	110	315S	2250	1800	2100		970	770	820	455	688	1700
	132	315M	2350	1900	2200		970	770	820	455	688	1800
	160	315M	2350	1900	2200		970	770	820	455	688	1900
125/06	90	280M	2350	1900	2200	870	670	720	440	802	1750	
	110	315S	2400	1950	2250	970	770	820	455	802	1810	
	132	315M	2450	2000	2300	970	770	820	455	802	1950	
	160	315M	2450	2000	2300	970	770	820	455	802	2050	
	185	315L	2500	2050	2350	970	770	820	455	802	2150	
	200	315L	2500	2050	2350	970	770	820	455	802	2150	

t: 320 mm

fig 0: Çıplak Pompa

fig 3: Pompa+Motor+Kaplin+Kaide

Ankraj Saplamları : M20X320

	Bağlantılar		WKL 125
	IM.1	G=ISO 228/1	
Monometre Bağlantısı	1M.1	G	1/2"
Sızdırmazlık Sıvı Çıkışı	14 A	G	3/8"
Sızdırmazlık Sıvı Girişi	10 E	G	3/8"
Akışkan Drenajı	6 B	G	1/2"
Akışkan Doldurma ve Hava Alma	6 D	G	1/2"
Sızıntı Drenajı	8 B	G	1/2"

WKL 150

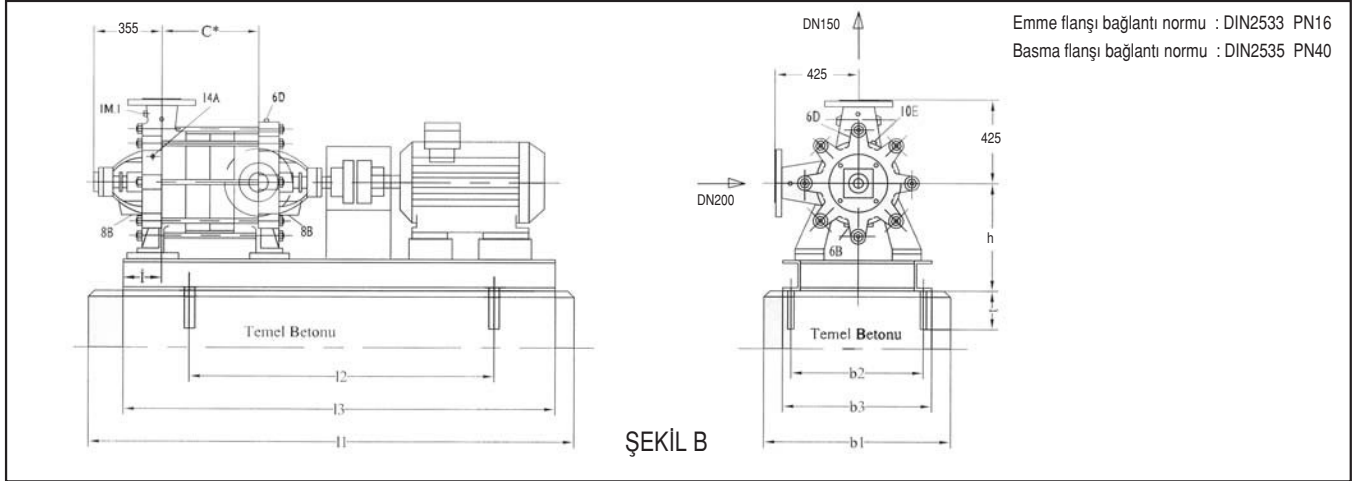

WKL	KW 1450	IEC	L ₁	L ₂	L ₃	l	b ₁	b ₂	b ₃	h	fig 0 kg	fig 3 kg
150/01	30	200L	1700	1250	1550	165	970	770	820	490	635	950
	37	225S	1700	1250	1550		970	770	820	490	635	993
	45	225M	1700	1250	1550		970	770	820	490	635	1035
	55	250M	1750	1300	1600		970	770	820	490	635	1050
	75	280S	1800	1350	1650		970	770	820	490	635	1360
150/02	37	225S	1850	1400	1700		970	770	820	490	760	1125
	45	225M	1850	1400	1700		970	770	820	490	760	1165
	55	250M	1850	1400	1700		970	770	820	490	760	1200
	75	280S	1950	1500	1800		970	770	820	490	760	1500
	90	280M	2000	1550	1850		970	770	820	490	760	1670
	110	315S	2150	1700	2000		970	770	820	490	760	1750
	132	315M	2150	1700	2000		970	770	820	490	760	1850
150/03	160	315M	2150	1700	2000		970	770	820	490	760	1950
	75	280S	2150	1700	2000		970	770	820	490	885	1620
	90	280M	2150	1700	2000		970	770	820	490	885	1800
	110	315S	2300	1850	2150		970	770	820	490	885	1875
	132	315M	2300	1850	2150		970	770	820	490	885	1980
	160	315M	2300	1850	2150		970	770	820	490	885	2100
150/04	185	315L	2370	1920	2220		970	770	820	490	885	2200
	200	315L	2370	1920	2220		970	770	820	490	885	2250
	110	315S	2350	1900	2200		970	770	820	490	1010	2005
	132	315M	2350	1900	2200		970	770	820	490	1010	2120
	160	315M	2350	1900	2200		970	770	820	490	1010	2220
150/05	185	315L	2500	2050	2350		970	770	820	490	1010	2325
	200	315L	2500	2050	2350		970	770	820	490	1010	2400
	132	315M	2550	2100	2400	970	770	820	490	1135	2250	
	160	315M	2550	2100	2400	970	770	820	490	1135	2350	
	185	315L	2550	2100	2400	970	770	820	490	1135	2470	
	200	315L	2550	2100	2400	970	770	820	490	1135	2520	
	250	355M	2750	2300	2600	1080	870	930	495	1135	2785	
315	355M	2750	2300	2600	1080	870	930	495	1135	3020		
355	355M	2750	2300	2600	1080	870	930	495	1135	3660		

t: 320 mm

fig 0: Çıplak Pompa

fig 3: Pompa+Motor+Kaplin+Kaide

Ankraj Saplamları : M20X320

	Bağlantılar		WKL 150
		G= ISO 228/1	
Monometre Bağlantısı	1M.1	G	1/2"
Sızdırmazlık Sıvı Çıkışı	14 A	G	3/8"
Sızdırmazlık Sıvı Girişi	10 E	G	3/8"
Akışkan Drenajı	6 B	G	1/2"
Akışkan Doldurma ve Hava Alma	6 D	G	1/2"
Sızıntı Drenajı	8 B	G	1/2"

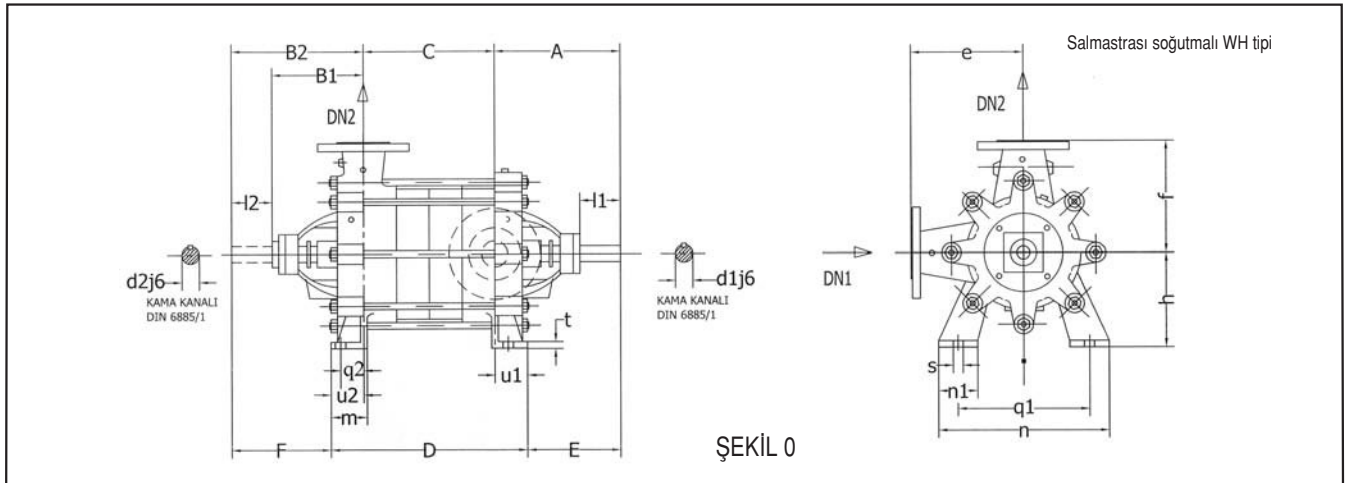

Pompa büyüklüğü	Pompa Ölçüleri																			Mil başı ölçüleri				
	Nws	NWd	A	B1	B2*)	D	E	F	e	f	h	m	n	n1	q1	q2	s φ	t	u1	u2	d1 φ j6	d2 φ j6*)	l1	l2
32	40	32	280	230	295	C+76	242	257	160	160	105	45	190	55	150	25	11.5	12	38	38	25	20	50	50
40	50	40	300	250	300	C+86	257	257	170	170	115	48	210	60	170	30	11.5	12	38	38	25	20	50	50
50	65	50	335	270	345	C+92	289	299	180	180	135	50	280	60	230	30	15	12	46	46	35	28	60	60
65	80	65	340	270	345	C+102	289	294	200	200	155	55	300	70	250	35	15	14	51	51	35	28	60	60
80	100	80	370	300	385	C+120	310	325	265	265	210	60	370	70	310	40	15	14	60	60	40	35	85	85
100	125	100	415	330	435	C+140	345	365	300	300	250	75	440	80	370	45	15	14	70	70	45	40	95	95
125	150	125	480	360	500	C+170	395	415	375	375	300	85	550	95	460	51	20	18	85	85	50	45	125	125
150	200	150	560	430	575	C+200	460	475	425	425	350	100	650	100	550	65	23	18	100	100	60	48	140	140

Pompa büyüklüğü	Kademe sayısına göre pompa C ölçüsü														
	1	2	3	4	5	6	7	8	9	10	11	12	13	14	15
32	67	112	157	202	247	292	337	382	427	472	517	562	607	652	697
40	70	120	170	220	270	320	370	420	470	520	570	620	670	720	
50	73	128	183	238	293	348	403	458	513	568	623	678			
65	87	147	207	267	327	387	447	507	567						
80	110	193	276	359	442	525	608	691	774						
100	135	235	335	435	535	635	735								
125	165	280	395	510	625										
150	215	360	505	650											

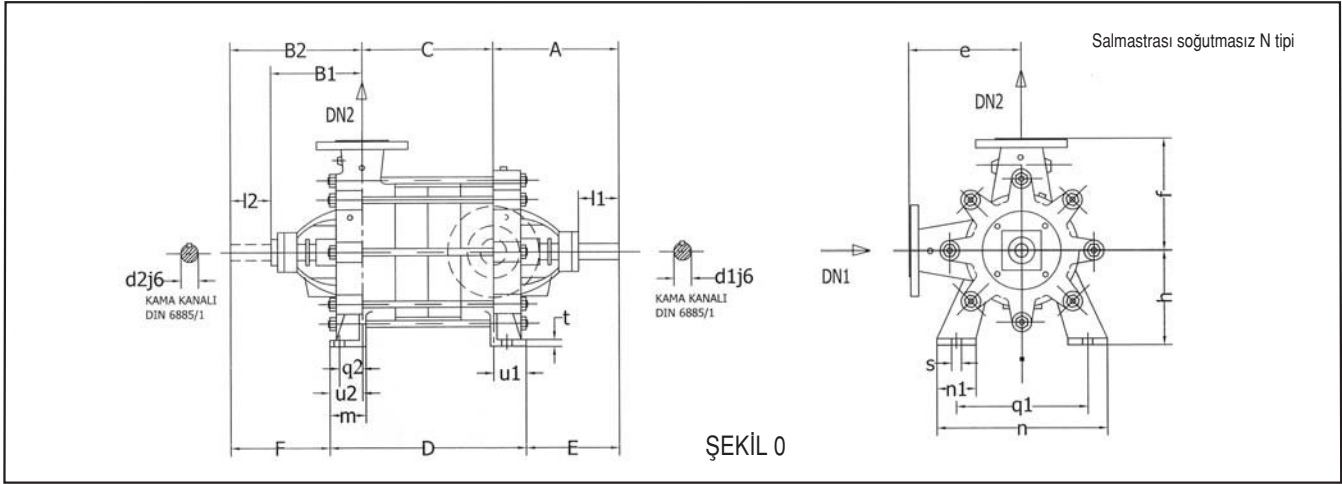

Teknik bilgilerde haber vermesizin değişiklik yapma hakkımız saklıdır.

Pompa büyüklüğü	Pompa Ölçüleri																		Mil başı ölçüleri					
	Nws	NWd	A	B1	B2*)	D	E	F	e	f	h	m	n	n1	q1	q2	s	t	u1	u2	d1 j6	d2 j6*)	l1	l2
32	40	32	235	185	245	C+76	197	207	160	160	105	45	190	55	150	25	11.5	12	38	38	25	20	50	50
40	50	40	250	200	260	C+86	207	217	170	170	115	48	210	60	170	30	11.5	12	43	43	30	25	50	50
50	65	50	285	220	295	C+92	239	249	180	180	135	50	280	60	230	30	15	12	46	46	35	28	60	60
65	80	65	290	220	295	C+102	239	244	200	200	155	55	300	70	250	35	15	14	51	51	35	28	60	60
80	100	80	320	250	335	C+120	260	275	265	265	210	60	370	70	310	40	15	14	60	60	40	35	85	85
100	125	100	360	275	380	C+140	290	310	300	300	250	75	440	80	370	45	15	14	70	70	45	40	95	95
125	150	125	420	300	440	C+170	335	355	375	375	300	85	550	95	460	51	20	18	85	85	50	45	125	125
150	200	150	485	355	500	C+200	385	400	425	425	350	100	650	100	550	65	23	18	100	100	60	48	140	140

E/1210 E/1-82

Pompa büyüklüğü	Kademe sayısına göre pompa C ölçüsü																
	1	2	3	4	5	6	7	8	9	10	11	12	13	14	15	16	17
32	67	112	157	202	247	292	337	382	427	472	517	562	607	652	697	742	787
40	70	120	170	220	270	320	370	420	470	520	570	620	670	720	770	820	
50	73	128	183	238	293	348	403	458	513	568	623	678	733	788			
65	87	147	207	267	327	387	447	507	567	627	687						
80	110	193	276	359	442	525	608	691	774	857							
100	135	235	335	435	535	635	735	835									
125	165	280	395	510	625	740											
150	215	360	505	650	795												

Ursan Pompa Armatür ve Endüstriyel Ürünler San. Tic. Ltd. Sti.

Güzeller Mah. Bağdat Cad. No: 601/A 41400 Gebze / KOCAELİ

Tel: (0.262) 642 05 60 - 641 84 15 - 641 82 60 Fax: (0.262) 642 39 79

e-mail: kocaali@ksb.com.tr - ursan@ursanpompa.com

www.ursanpompa.com