

► Our technology. Your success.

Pumps • Valves • Service

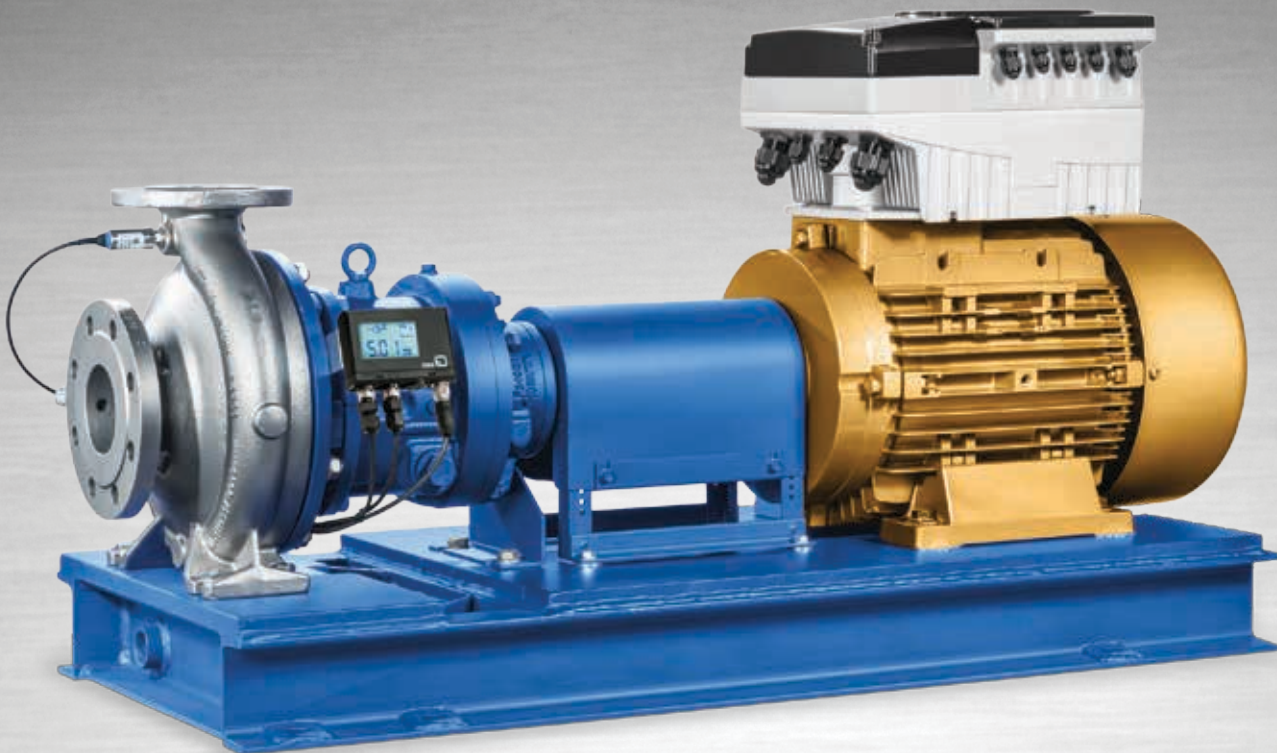

Magnochem – Standardised Chemical Pump with Magnetic Coupling



Applications:

For handling aggressive, toxic, explosive, valuable, flammable, malodorous or harmful fluids in the chemical, petrochemical and general industries.

More information: www.ksb.com/products

Magnochem – Standardised Chemical Pump with Magnetic Coupling

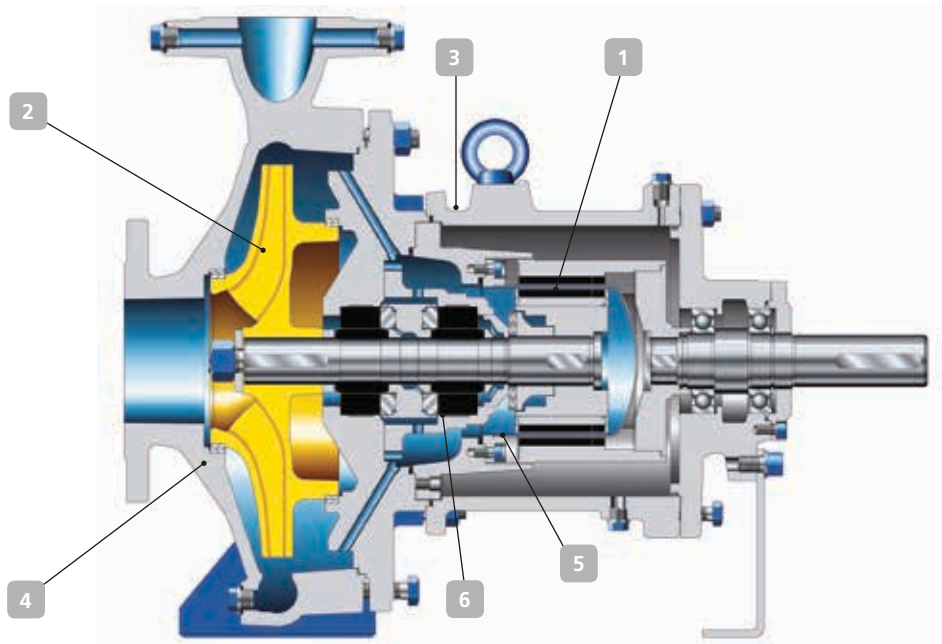

1 Further development of the tried and tested mag-drive pump

- Optimised modular system for magnetic couplings
- Multiple patents pending

2 Expanded performance range

- New sizes (a total of 58 hydraulic system sizes)
- Expanded temperature range
- New operating modes
- Suitable for new applications

3 Broad range of variants for excellent flexibility

- Wide range of technical design options
- Modular design system able to match every customer requirement

4 Excellent energy efficiency

- Modern, energy-efficient design
- Optimised hydraulic system
- Ceramic loss-free containment shroud as standard

5 Maximum operating reliability and environmental acceptability

- optional DLC-coated plain bearings made of silicon carbide with optimised dry-running properties
- No more than two static seals required
- Optional leakage barrier

6 High availability and low operating costs

- Reduction in required stock levels
- Improved mean time between failures

KSB as competent and experienced partner

Comprehensive product portfolio for conventionally sealed pumps, mag-drive and canned motor pumps

Technical data	50 Hz	60 Hz
Flow rate up to	1160 m ³ /h	1400 m ³ /h
Head up to	162 m	233 m
Fluid temperature	-90 °C to +300 °C	
Operating pressure up to	40 bar	40 bar



KSB SE & Co. KGaA
 Johann-Klein-Straße 9
 67227 Frankenthal (Germany)
 www.ksb.com